

## IR-FREON-D

### FREON GAS TRANSMITTER/SENSOR

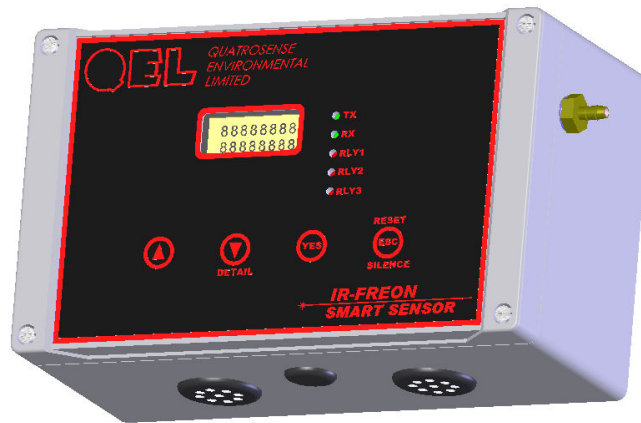

## INSTALLATION OPERATION AND MAINTENANCE MANUAL

QUATROSENSE ENVIRONMENTAL LTD.  
5935 OTTAWA STREET, PO BOX 749 RICHMOND, ONTARIO CANADA K0A 2Z0  
PHONE: (613) 838-4005 FAX: (613) 838-4018  
Web: [www.QELsafety.com](http://www.QELsafety.com) Email: [QEL@QELsafety.com](mailto:QEL@QELsafety.com)

## Table Of Contents

<b>READ BEFORE OPERATING .....</b>	<b>3</b>
<b>1. GENERAL INFORMATION .....</b>	<b>3</b>
1.1 PRINCIPLE OF OPERATION .....	3
1.2 KEY FEATURES .....	4
1.3 APPLICATIONS.....	4
1.4 SPECIFICATIONS .....	5
<b>2. INSTALLATION .....</b>	<b>7</b>
2.1 SENSOR LOCATION.....	7
2.2 PHYSICAL DIMENSIONS .....	8
2.3 GAS SAMPLING .....	8
2.4 MOUNTING AND SYSTEM WIRING .....	8
2.4.1 Terminals.....	9
2.4.2 Power Supply.....	9
2.4.3 Wire and Cable.....	10
2.4.4 Digital Connection .....	10
2.4.5 RS-485 Terminator.....	10
2.4.6 RS-485 Driver Replacement.....	11
2.4.7 4-20mA or 2-10VDC Analog Output.....	11
2.4.8 Relays Output .....	12
<b>3. FUNCTION AND CONFIGURATION .....</b>	<b>13</b>
3.1 IR-FREON-D WORKING MODE .....	13
3.2 SYSTEM INITIALIZATION.....	13
3.3 KEYPAD .....	13
3.4 STATUS LED.....	15
3.4.1 RS485-TX/RX:.....	15
3.4.2 Relay1-3 LED:.....	15
3.5 LATCHED RELAY RESET.....	15
3.6 HUSH BUZZER AND HORN.....	15
3.7 IR-FREON-D MAIN MENU TREE .....	15
3.8 MENU “1_SYSTEM SETTING” .....	17
3.8.1 System Settings .....	18
3.9 MENU “2_ZEROING CALIBRATION”.....	20
3.9.1 Equipment Required.....	20
3.9.2 Zeroing Calibration Procedure.....	20
3.10 MENU “3_SPAN CALIBRATION” .....	22
3.10.1 Span Calibration Procedure.....	22
3.11 MENU “4_OUTPUT TESTING” .....	23
3.12 MENU “5_SITE SERVICE” .....	23
3.13 MENU “6_RELAY DATABASE” .....	24
3.13.1 Relay Configurations .....	24
3.13.2 Relay Database Flow Chart .....	26
3.14 MENU “7_A-OUT DATABASE” .....	27
3.15 MENU “8_BUZZER DATABASE” .....	28
3.16 MENU “9_OUTPUT DISABLE” .....	28
3.17 MENU “10_SIMU DISABLE” .....	28
<b>4. MODBUS PROTOCOL SUPPORTED BY IR-FREON-D.....</b>	<b>28</b>
<b>5. MAINTENANCE.....</b>	<b>29</b>

# IR-FREON-D Operation And Maintenance Manual

5.1	DVM CONNECTION FOR 4-20MA MEASUREMENT .....	29
5.2	4MA AND 20MA OUTPUT CALIBRATION .....	29
<b>6.</b>	<b>TROUBLESHOOTING .....</b>	<b>30</b>

## READ BEFORE OPERATING

All individuals who have or will have the responsibility of using, maintaining, or servicing this product must carefully read this manual. The product will perform as designed only if it is used, maintained, and serviced in accordance with the manufacturer's instructions.

### 1. General Information

#### 1.1 Principle of Operation

The IR-FREON-D Smart Sensor is a microprocessor controlled FREON gas Sensor or Transmitter using infrared sensing technology. The concentration of Freon is measured by determining the amount of absorption of light in a specific frequency band.

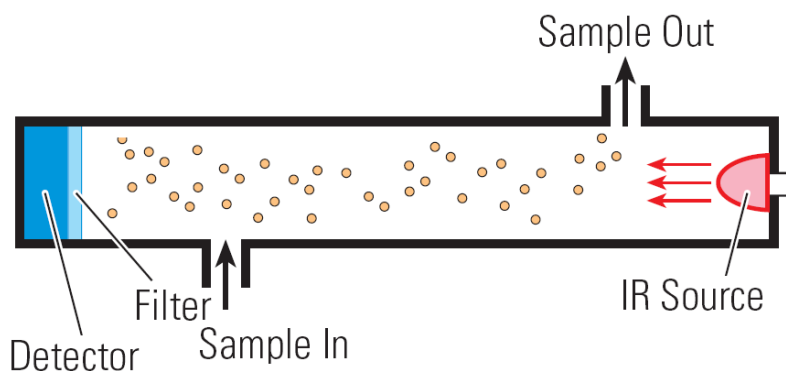

As most gases have their characteristic spectra in the infrared. Those spectra derive from the molecule's composition in such a way that no two molecular gases have the same IR spectrum. IR spectra are the fingerprints of gases, and thus allow gases to be uniquely identified.

By transmitting a beam of IR radiation through the air, or through any particular gas volume, and recording how much is transmitted at selected spectral lines, one may decide which gases are present and how much of each. This is a standard and well-proven principle, routinely used in laboratory analyses of chemical species, and is also the basis on which our sensors are made.

An IR detector is essentially a temperature sensor and is, therefore, potentially very sensitive to changes in the ambient temperature. However, our IR-FREON-D smart sensor modules do it better, faster, and more precisely. The IR-FREON-D smart sensors are entirely electronic with no moving parts, and are built around our unique QT Gas Sample Cell with constant temperature control integrated with IR Source and IR Detector together. This makes our IR smart sensors work from  $-45^{\circ}\text{C}$  to  $65^{\circ}\text{C}$  without being susceptible to ambient temperature fluctuations.

Comparing with conventional gas detector, gases to be detected are often corrosive and reactive. With most sensor types, the sensor itself is directly exposed to the gas, often causing the sensor to drift or die prematurely. The main advantage of IR sensor or transmitter is that the detector does not directly interact with the gas (or gases) to be detected. In the IR-FREON-D Smart Sensor, the major functional components are protected with optical parts. In other words, gas molecules interact only with a light beam. The IR Source and IR Detector can be treated, making them resistant to corrosion, and are designed such that they are easily removable for maintenance or replacement.

## **1.2 Key Features**

- Infrared Sensing Technology
- Constant Temperature QT Gas Sampling Cell
- Standard RS-485 Output with OptoMux protocol and ModBus protocol
- Standard 4-20mA or 2-10VDC Analog Output
- Diffusion Sampling module or Pump-thru module
- No moving parts in diffusion or pump-thru model
- Water and corrosion resistant PVC enclosure NEMA 4, 4X
- Addressable from 0 to 31
- 4 magnetic sensors as keypad input
- 3 programmable Relays and 3 programmable Buzzers
- 2 x 8 character LCD display c/w backlight
- Operation at 18-30VDC or 15–24VAC
- 3 Relay Status LED, TX Status LED and RX Status LED
- CSA/UL approval (pending)

## **1.3 Applications**

The IR-FREON-D is designed to monitor for the loss of refrigerant gas in a variety of applications:

- Mechanical equipment rooms
- Propellant filling operations
- Solvent cleaning stations
- Cold storage and transport facilities
- Meat packing plants
- Supermarkets and refrigerant storage locations
- Other specialty applications using halocarbons

## 1.4 Specifications

<b>Input Power:</b>	24VDC nominal, range 18 to 30VDC, 1.0A DC Total Max. 24VAC nominal, range 15 to 24VAC, 1.0A AC Total Max.
<b>Fuse:</b>	F1 on Display Board: Polyswitch 1.6A F2 on Display Board: Polyswitch 50mA Polyswitch device resets after the fault is cleared and power to the circuit is removed
<b>Sensor:</b>	Infrared Freon
<b>Gas Detected: (My Sensor Ver 3.04 or later)</b>	User selectable: R134A, R22, R11, R114, R402A, R404A, R407C, R408A, R409A, R410A, R422, R438A, R507A Available on special order: R12, R13, R14, R21, R23, R31, R32, R41, R113, R115, R116, R123, R125, R143a, R152, R161 ...
<b>Range:</b>	0 to 100ppm for R123; 0 to 1000ppm for others
<b>Accuracy:</b>	±3% of reading
<b>Repeatability:</b>	±1% of full scale
<b>Sampling:</b>	Diffusion or Pump-through
<b>Panel Indicators:</b>	5 Status LED's <ul style="list-style-type: none"> <li>• RS-485 TX Status (Green)</li> <li>• RS-485 RX Status (Green)</li> <li>• Relay1 Status (Red)</li> <li>• Relay2 Status (Red)</li> <li>• Relay2 Status (Red)</li> </ul>
<b>Display:</b>	2 x 8 character display c/w backlight
<b>Keypad:</b>	4 magnetic sensors with Magnet tool
<b>Relays:</b>	3 Relays SPDT, Dry contacts <ul style="list-style-type: none"> <li>• 1.0A maximum at 30 VDC (resistive load)</li> <li>• 0.3A maximum at 125VAC (resistive load)</li> </ul>
<b>Buzzer:</b>	80 db at 10 cm, 2700 Hz Buzzer 1: Double-tap Intermittent Buzzer 2: Intermittent 50% duty cycle

	Buzzer 3: Continuous
<b>Output Signal:</b>	RS-485 with OptoMux protocol <ul style="list-style-type: none"><li>• Available Controller: M-Controller Q4 Controller</li></ul> RS-485 with ModBus protocol 4-20mA or 2-10VDC Analog Signal
<b>Enclosure Rating:</b>	IP 66 & NEMA 4, 4X, 12 & 13 Cover Screws should be torqued to 2.5lbs-in (30cN-m)
<b>Operating Temperature:</b>	-45°C to 65°C
<b>Ambient Humidity:</b>	5% to 95% RH (non-condensing)
<b>Storage Temperature:</b>	-45°C to 70°C
<b>Size:</b>	200mm X 120mm X 90mm
<b>Weight:</b>	Less than 1.5lbs (0.680 kg)

## 2. Installation

### 2.1 Sensor Location

Several factors should be considered when selecting locations to install sensors. The following general suggestions should be considered to assure the detection of the target gas. Select the most suitable location for each sensor. All mounting locations must be fixed, well supported wall, pole or frame with no vibrations. If such a location is not close to the source of a potential leak, we offer the SCS-1 sample-conditioning pump.

1. Air Currents: If there are fans, winds, or other sources of air movement, gases may tend to rise or collect in certain areas of a facility. The local air currents should be assessed by such means as smoke candles to aid in selecting the sensor location. The maximum airflow past the sensor should not exceed 3 feet per second. Air velocity past the sensor can be determined by lighting a match close to the sensor. If the match is blown out by the air current, a sample-conditioning pump such as the SCS-1 should be considered. Alternatively, stagnant air will not diffuse into the sensor, again, the SCS-1 (One channel sampling and conditioning system) should be considered. In outdoor situations consideration such as prevailing winds should be accounted for. Air convection can often be more important in determining gas concentrated areas than factors of vapor density.
2. Vapor Density: Halocarbon refrigerants such as R11, R22, R123, and R134a are heavier than air. Detecting location should be 9-18 inches (0.23m to 0.46m) above the floor. If such a location is not close to the source of a potential leak, we offer the SCS-1 sample-conditioning system.
3. Gas Emission Sources: As a rule, at least one sensor should be located in close proximity to each point where a leak is likely to occur. This is particularly important when a liquid having a low volatility is monitored. If there is not a suitable mounting location close to the potential source of a leak, we offer the SCS-1 sample-conditioning system.
4. Environmental Factors: Designed to rugged outdoor use, consider the following in selecting locations. Avoid locations where there are high vibrations, large temperature fluctuations, or large pressure changes. Using the SCS-1 (One channel sampling and conditioning system ) should be considered in such locations. Install sensor where they will be protected from wind, dust, snow, water and shock.
  1. Air Currents: If there are fans, winds, or others sources of air movement, gases may tend to rise or collect in certain areas of a facility. The local air currents should be assessed to aid in selecting the sensor location. In outdoor situations considerations such as prevailing winds should be accounted for. Air convection can often be more important in determining gas concentrated areas than factors of Vapor Density.

## 2.2 Physical Dimensions

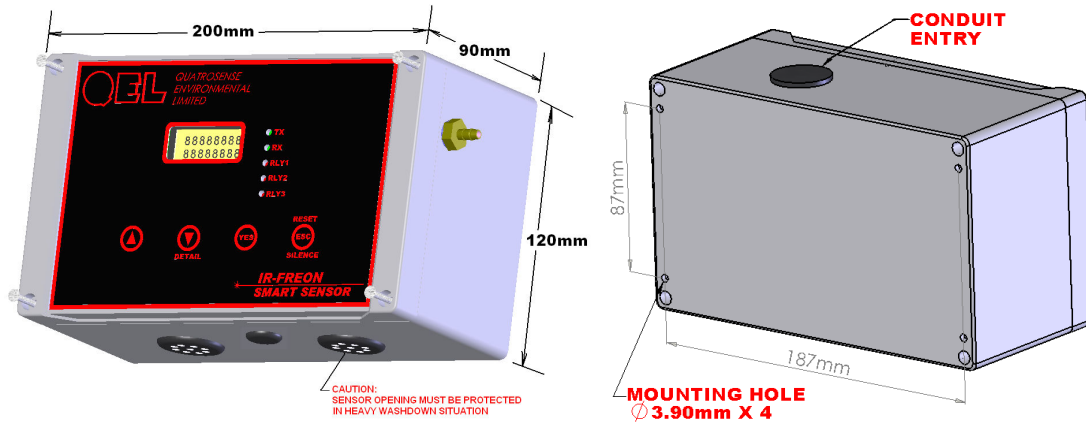

## 2.3 Gas Sampling

In Diffusion version IR-FREON-D, the gas sampling system is composed of a diffusion type gas sample chamber and two vent holes on the enclosure bottom. The gas flows in and out through the two vent plugs on the bottom of the IR-FREON-D enclosure. See above picture.

In Pump-thru version IR-FREON-D, the sampling gas is pumped through the fitting on the bottom of the IR-FREON-D enclosure, and passed through the gas chamber, then exhausted out though the fitting on the right side of the enclosure. **Pump-thru version IR-FREON-D doesn't have pump inside.** For gas sampling and conditioning unit, QEL provides SCS-1 (One channel sampling and conditioning system).

## 2.4 Mounting and System Wiring

**NOTE:** The Diffusion version IR-FREON-D should be mounted 1 foot (30cm) from the floor. Otherwise the SCS-1 (One channel sampling and conditioning system) should be considered.



Mounting brackets provided for wall installation

## 2.4.1 Terminals

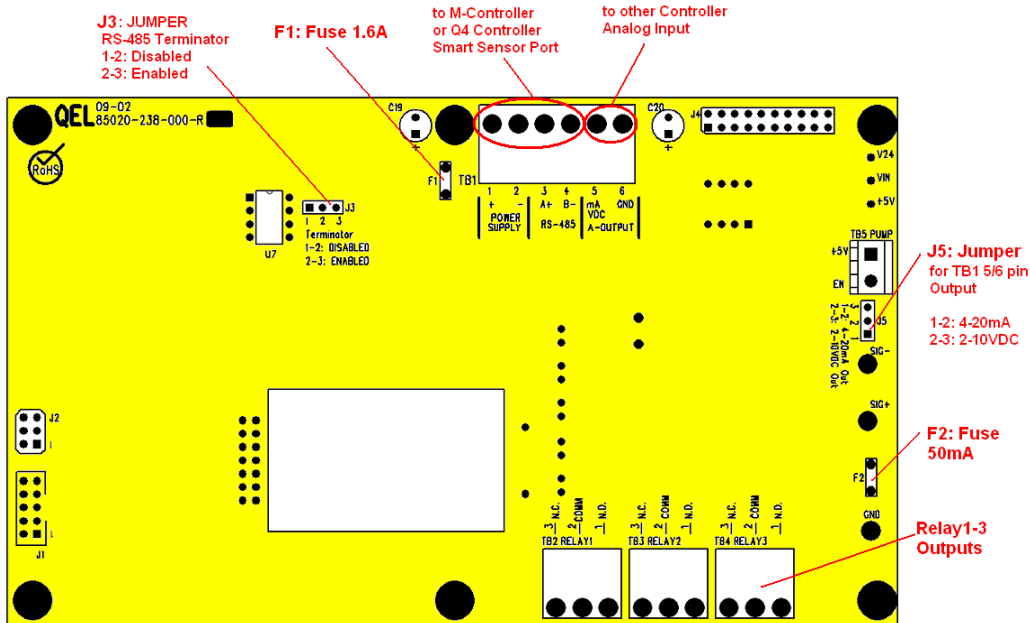

Display Board Terminals

## 2.4.2 Power Supply

**NOTICE:** Installing or using this equipment in a manner not specified by the manufacturer could cause electric shock, bodily injury, or risk of fire.

Power Supply:

Voltage:	15-24VAC	50/60Hz	1.0A AC Total max.
	18-30VDC		1.0A DC Total max.

**Note:** AC Power must be non-grounded (floating).

**Note:** No external over-current protection is required. Over-current protection is provided by means of fuses F1.

Fuse F1: PolySwitch 1.6A

### 2.4.3 Wire and Cable

The terminal block plug TB1 accepts 12 AWG to 24 AWG wire, Use 16 AWG or 18 AWG wire for Power Supply in long wiring runs, which can be up to 1km (1,000 meters) long.

We recommend using BELDEN 9841 for communications. This wire has 120 ohm input impedance, which will eliminate RS-485 communication problems.

### 2.4.4 Digital Connection

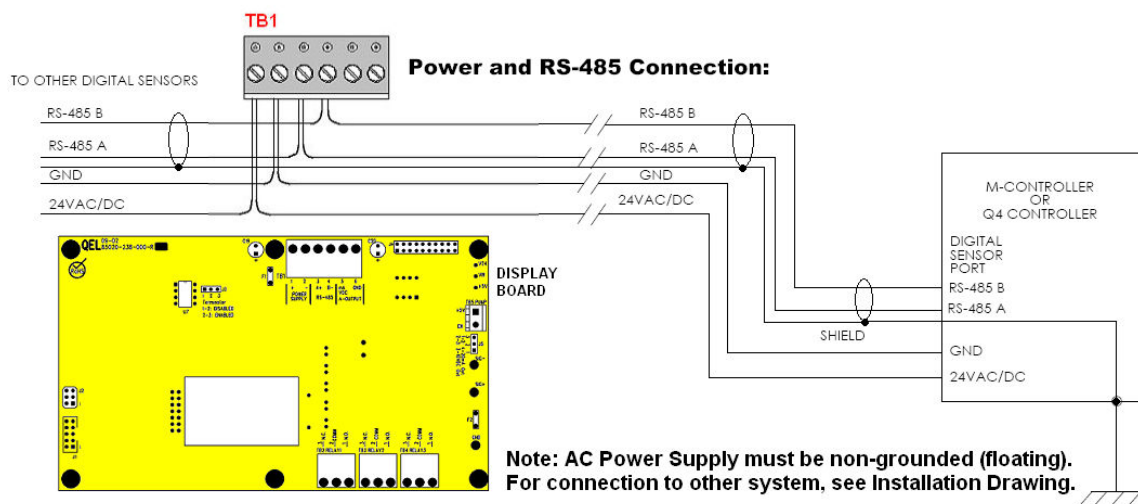

### 2.4.5 RS-485 Terminator

The terminator on each end of the RS485 loop is designed to match the electrical impedance characteristic of the twisted pair loop, and will prevent signal echoes from corrupting the data on the line. The terminator should be enabled on BOTH ends of the RS485 loop. Short and medium length modbus/485 loops can operate without the terminating resistor. Longer runs may require the terminating resistors. But adding terminator dramatically increases power consumption.

**Factory default setting is disabled terminator.**

The IR-FREON-D smart sensor supplies this resistor on the display board, and it is chosen using a jumper at J3.

- J3 1-2: Terminator Disabled / OFF (default)
- J3 2-3: Terminator Enabled / ON

### 2.4.6 RS-485 Driver Replacement

RS-485 lines in heavy industrial environments are sometimes subjected to magnetic disturbances causing sufficient inducted power surges to damage the driver integrated circuit (IC). This IC U7 has a socket on the circuit card for ease of replacement in the field.

### 2.4.7 4-20mA or 2-10VDC Analog Output

IR-FREON-D can provide one channel 4-20 milliamp analog outputs or 2-10VDC analog output. The maximum output impedance is 600 ohms for 4-20mA output. The maximum output current is 10 mA for 2-10VDC output.

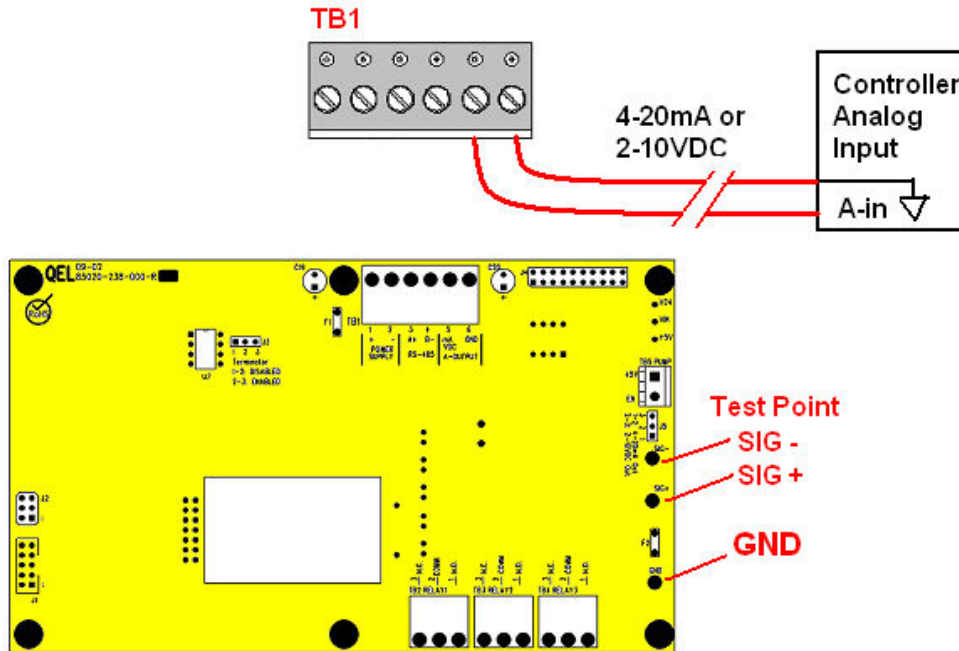

Test point SIG+ and SIG- are used to measure the current online when the IR-FREON-D is working in the field.

The module can also be used to output 2-10VDC if the Jump J5 2-3 is connected. The default setting: J5 1-2 is connected that mean the output is 4-20mA analog output.

The analog output may be defined in complex ways allowing assignment of different values to both 4 milliamps and 20 milliamps. You may even assign a gas concentration to 4 mA, which is higher than the concentration assigned to 20 milliamps. The IR-FREON-D will draw a straight line between.

If there is any fault found in IR-FREON-D, it will output 2.5mA to indicate the fault.

### 2.4.8 Relays Output

IR-FREON-D is equipped with three programmable Single-Pole Double-Throw (SPDT) Relays on board, which is able to make it work alone to control other equipment, such as fans, lights, horns, or visual alarm indicators in different applications.

Three terminal blocks TB2, TB3 and TB4 are located on the Display Board. Each relay can be programmed individually.

Switching capability of each relay is:

- 1.0 A maximum resistive load at 30 VDC
- 0.3A maximum resistive load at 125VAC

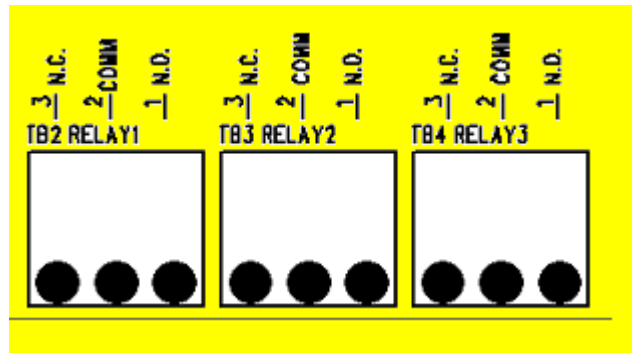

## 3. Function and Configuration

### 3.1 IR-FREON-D Working Mode

IR-FREON-D has four kinds of working mode:

- Warm-up Mode: to heat up Optical Block and initialize components.
- Monitoring Mode: to measure the gas concentration and output signals.
- Zeroing Calibration Mode: IR-FREON-D is performing Zeroing Calibration.
- Span Calibration Mode: IR-FREON-D is performing Span Calibration.

### 3.2 System Initialization

When the IR-FREON-D smart sensor is turned on, it initializes hardware and software. As the transmitter is warming up, the optical block is heated to a constant temperature, the LCD will display the transmitter is in warming-up procedure.

In warming-up procedure, the reading of the transmitter will always be zero and the analog output will always be 4mA. M-Controller and Q4 Controller will display “Warming up” in their LCD display panel. The time for warming-up procedure depends on the ambient temperature and input power voltage. The lower the ambient temperature and input voltage are, the longer it takes. Normally, at 25°C and 24V input voltage, it takes 45 minutes during the warming-up procedure.

After warming-up procedure, the transmitter automatically starts testing for errors. If there is an error, the LCD will display the error and the TB1 pin 5/6 will output 2.5mA if the 4-20mA analog outputs is enabled or 1.25VDC if the 2-10VDC analog outputs is enabled. An error message will display on the M-Controller or Q4 Controller panel.

**Note: After warming-up procedure, an error [PH-DIRTY] might appear, which is caused by low ambient temperature or low input power voltage. The error will disappear when unit is fully stabilized. If not, see section 6. Troubleshooting.**

**Note: No adjustments or calibration should be performed within 24 hours.**

### 3.3 Keypad

IR-FREON-D has four keys on the front panel. To access the keypad, the magnet tool in the product-shipping package is needed.

- Key [Up]: Scroll and Hold
- Key [Down]: View current input or output details
- Key [ESC]: Return to previous menu or Hush Buzzer or Reset Latched Relay
- Key [YES]: Enter Menu or Confirm answers

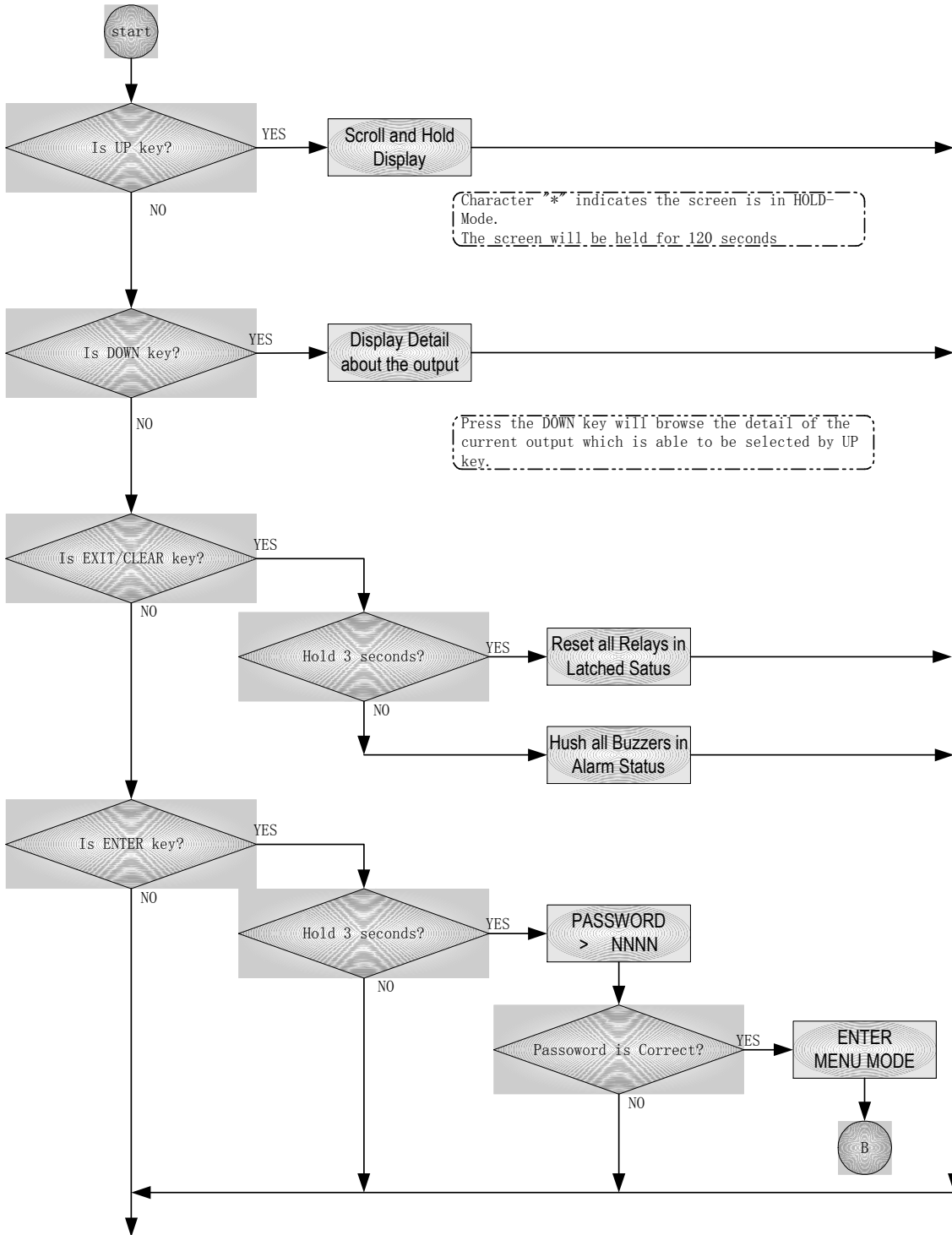

IR-FREON-D Running Mode Key Functions Flow Chart

### **3.4 Status LED**

#### **3.4.1 RS485-TX/RX:**

When the IR-FREON-D is connected to a Controller System through RS-485, the traffic of the communication can be monitored visually through the two RS-485 indicators. One is RX LED, which indicates the data stream received in the Controller. The other is TX LED, which indicates the data stream out of the IR-FREON-D.

**Note: If the TX LED or the RX LED is always ON, that means the communication has a problem. See Troubleshooting for RS-485.**

#### **3.4.2 Relay1-3 LED:**

Indicate the status of each relay. When the relay is actuated/closed, the Relay LED is ON. When the relay is de-actuated/open, the relay LED is OFF.

**Note: If you set the relay to be Normally Energized Relay (Fail Safe), the relay LED will turn ON at non-alarm state and turn OFF at alarm state, because the LED reflects the relay coil status.**

### **3.5 Latched Relay Reset**

To acknowledge a latched condition, press Key [ESC] for 3 seconds. All latched relays for which the alarm condition has been removed will reset. If the alarm condition (e.g. high gas concentration) is still present the relay(s) will not reset.

### **3.6 Hush Buzzer and Horn**

Press Key [ESC] to silence the buzzer and horn. Press the Key [ESC] again to remove the hush function.

### **3.7 IR-FREON-D Main Menu Tree**

Menu is password protected. Press and hold Key [YES] for 3 seconds, you will be prompted to input a four-digit password. Once the password is accepted, you are allowed into the main menu tree. Press button [Up] or [Down] to scroll through the main branch headings, press button [YES] to enter the function, press button [ESC] to exit to up level menu.

**Factory default password is 4321.**

**Note: While in the Menu Tree, all normal monitoring operations stop. The alarm status does not change.**

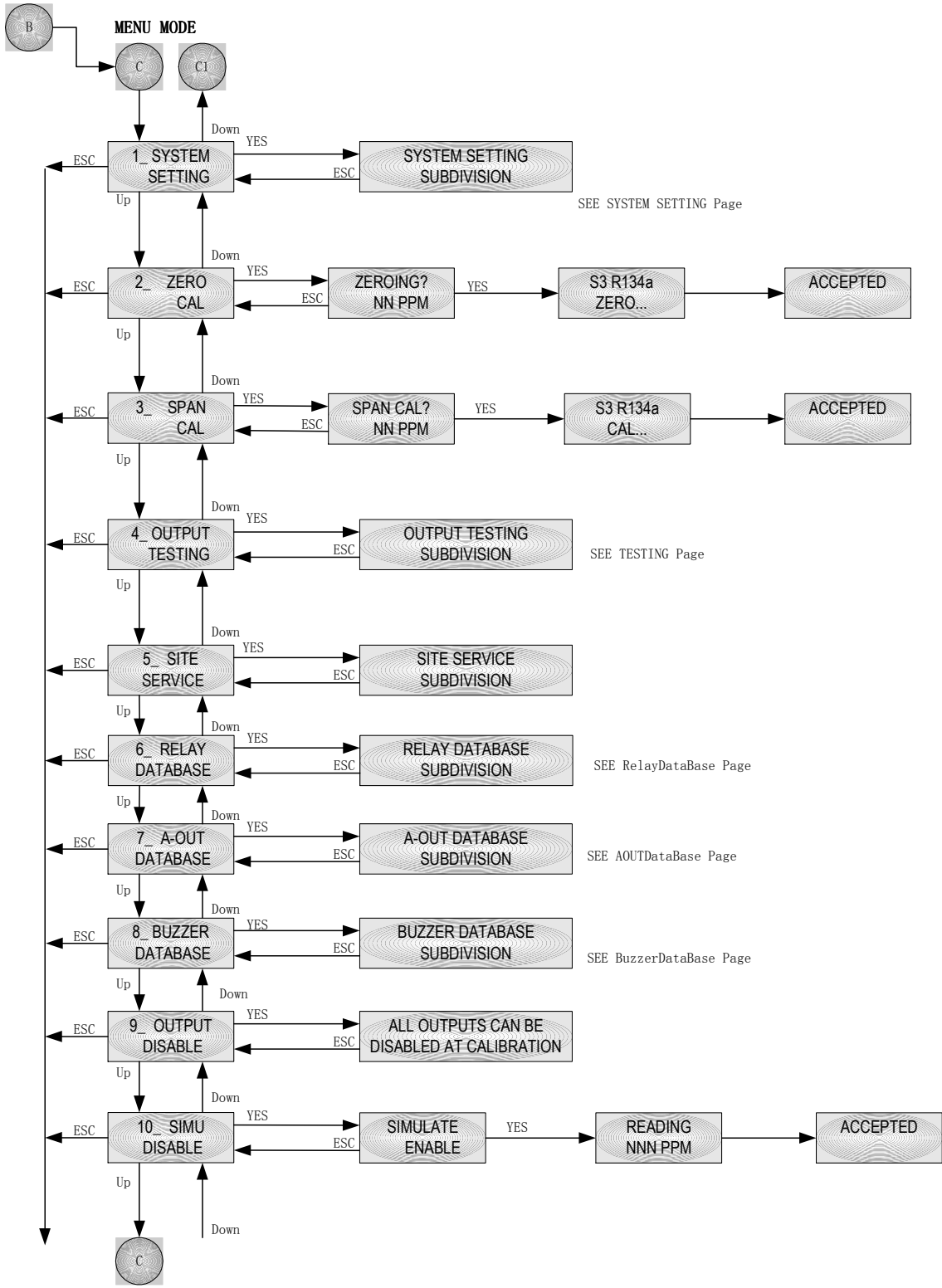

+

**IR-FREON-D Menu Tree Flow Chart**

### 3.8 Menu "1\_System Setting"

System Setting Subdivision contains general settings for monitor operations, communications and 4-20mA calibrations.

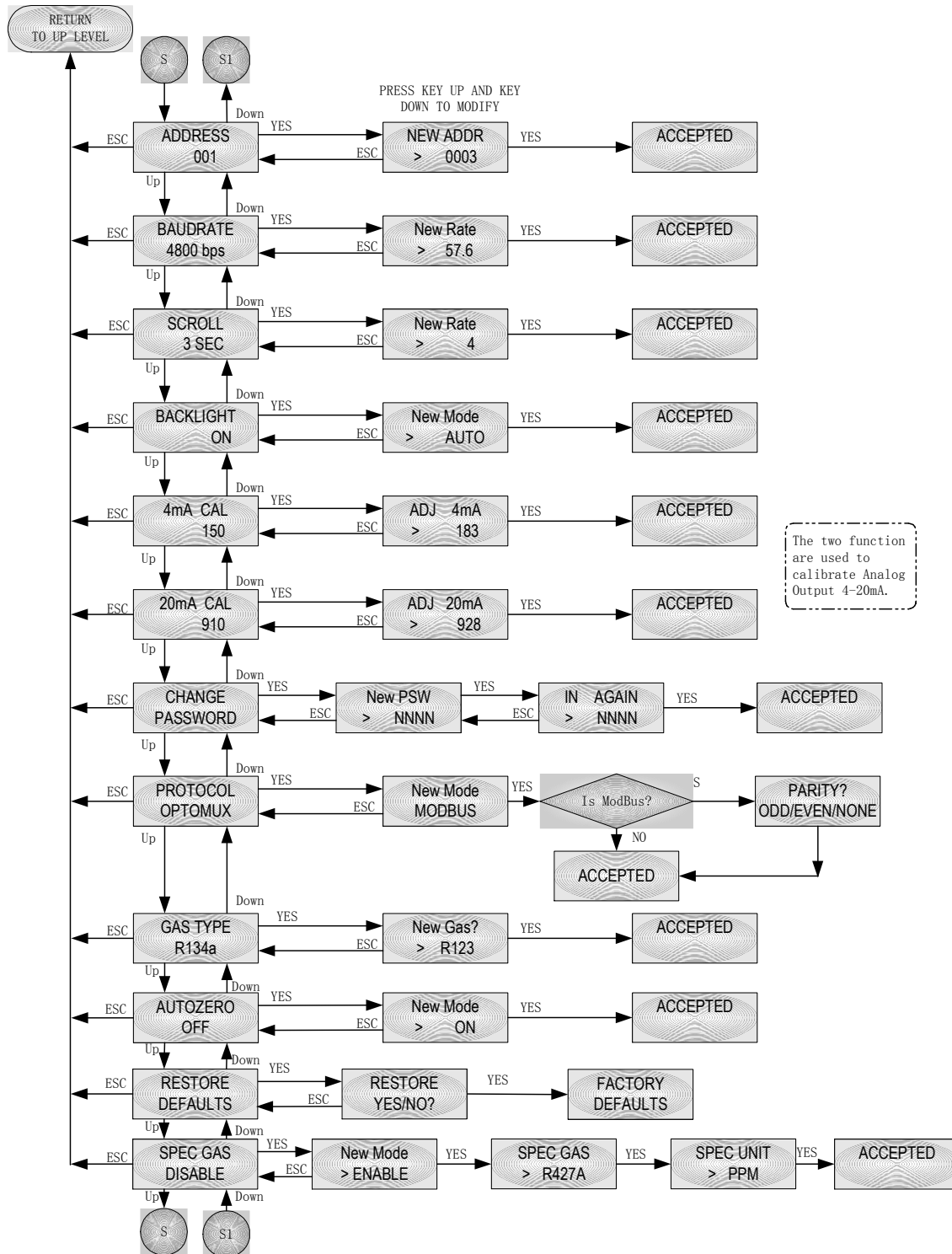

### 3.8.1 System Settings

<b>Password:</b>	Default password is 4321.
<b>Address:</b>	M-Controller supports RS-485 addressing from 0 to 31 for digital sensor. Q4 Controller supports RS-485 addressing from 0 to 3 for digital sensor. The IR-FREON-D smart sensor RS-485 address can be defined from 0 to 255 to be used in RS-485 OptoMux or ModBus communication. Default address is 3.
<b>Baud rate:</b>	Define Baud Rate for RS-485 OptoMux or ModBus Communication. Default baud rate is 4800 bps.
<b>Scroll Rate:</b>	In normal operation the sensor and relay status information scrolls automatically. Set the number of seconds for each item to be displayed. Default value is 3 seconds.
<b>Backlight:</b>	The LCD backlight can be set to Always Off, Always On and Power Saver. In Power Saving mode, the backlight will turn on for 10 seconds after any Key has been pressed. Default setting is Always ON mode.
<b>4mA Cal 20mA Cal:</b>	<p>These values are established during factory calibration for 4-20mA analog output and should not require recalibration in the field. Do not attempt to modify these settings in the field.</p> <p>Changing these values will change the analog output signal scale.</p> <p><b>Warning: This procedure is part of factory setup. In most circumstances it will not be necessary to perform this procedure in the field. These functions require the use of precision reference instrumentation.</b></p>
<b>Change Password:</b>	<p>Change Password allows any combination of up to four digits. Default password is 4321.</p> <p><b>Warning: Be sure that you record the new password in a safe and secure location!</b></p>
<b>Protocol:</b>	<p>When IR-FREON-D is connected to M-Controller or Q4-Controller, the protocol should be set to “OptoMux”. Default protocol is OptoMux.</p> <p>IR-FREON-D also supports “ModBus” protocol, responds as a ModBus Slave using RTU protocol. When it’s set to “ModBus”, the parity bit can be defined as “EVEN”, “ODD” and “No Parity”.</p>

<p><b>Gas Type</b></p>	<p>Default Gas Type is R134a.</p> <p><b>Note: All units are gas calibrated using 1000ppm R134a in factory. You can change the Gas Type to other target gas type without using target gas to calibrate again.</b></p> <p><b>For the gas type that IR-FREON-D supports, see 1.4 Specifications</b></p> <p><b>For other gas types, please consult QEL.</b></p> <p>Note: When the unit is connected to Q4 Controller, Q4 Controller can poll out the Gas Type automatically and display the gas type in its LCD display. When the unit is connected to M-Controller, the M-Controller will only use the Gas Type and Measurement Unit that are defined for the channel in M-Controller.</p>
<p><b>AutoZero:</b></p>	<p>When “AutoZero” is set to “ON”, the IR-FREON-D will gather the lowest ppm reading in an 7-day period and set the unit Zeroing Calibration so that the lowest reading goes to zero. When “AutoZero” is set to “OFF”, the unit will not adjust its own calibration and work off the last manual or factory calibration.</p> <p>Default AutoZero is ON in My Sensor Ver 3.01 or later.</p> <p><b>NOTE: “AutoZero” works best in situations where the facility is exposed to non-refrigerant-existing air at least four times in 7 days. In facilities that are continuously occupied for 24 hours per day, or where there could be significant sources of non-occupant related refrigerant gas, the Auto Zero should be turned OFF.</b></p>
<p><b>Restore Default:</b></p>	<p>To load defaults to all items. Perform a full factory and gas calibration to restore the unit to correct operation. After restore default, the unit needs to be recalibrated with Zeroing Calibration and Span Calibration</p>
<p><b>Special Gas:</b></p>	<p>When the unit is calibrated to a special gas type that is not listed in above Gas Type list, you can enable the Special Gas Type and input the special Gas Type and Measurement Unit, which will override the Gas Type defined in above Gas Type Menu for IR-FREON-D LCD display and Q4 Controller LCD display.</p>

### 3.9 Menu “2\_Zeroing Calibration”

Calibration should not vary significantly over a period of years; however, it is best to perform a verification calibration after installation, and at one-year intervals thereafter. All units are factory calibrated.

The IR-FREON-D uses full scale as its CAL GAS concentration:

Basically, IR-FREON-D full scale for all Freon gases is 1000ppm except for R123, which is 100ppm.

Gas Type	Full Scale	Cal Gas Concentration
R134a	1000ppm	1000ppm
R123	100ppm	100ppm
R22	1000ppm	1000ppm
R11	1000ppm	1000ppm
Others	1000ppm	1000ppm

The IR-FREON-D smart sensor is calibrated using a two-point calibration process. First, use a “Zero Gas”, then use a “CAL Gas” containing a known concentration of a standard reference gas, to set the second point of reference.

#### 3.9.1 Equipment Required

- A cylinder of Zero Gas: it can be clean room air or Zero Air (20.9% Oxygen in Nitrogen). **DO NOT USE PURE NITROGEN.**
- A cylinder of Cal Gas (balanced with air, **DO NOT USE BALANCED WITH NITROGEN**)
- Flow Limiting Regulator(s) **0.4 to 0.6 lpm**
- Tubing

#### 3.9.2 Zeroing Calibration Procedure



Zeroing Calibration Flow Chart

**Note: No adjustments or calibration should be performed within 24 hours stabilization.**

**Note: Zeroing Calibration must be performed before Span Calibration.**

1. Connect tubing to IR-FREON-D

- For Diffusion Version: Connect the zero gas supply tubing to the fitting on the right side of enclosure

- For Pump-through Version: Connect the zero gas supply tubing to the push-in fitting on the bottom side of enclosure
2. Turn on the gas flow and press Key [YES] to display current reading



This screen is displaying the current reading and asking if you want to perform Zeroing Calibration.

3. Waiting for about 3 minutes or till the reading is stable.
4. Press Key [YES] to perform Zeroing Calibration.
5. During Zeroing Calibration, the LCD will display the digital pot positions and calibration statuses. It will take 3 to 10 minutes to perform Zeroing Calibration, then the zero calibration data is saved and LCD displays "Accepted".
6. If the LCD displays "Cal Error" that means something is wrong in the procedure, repeat procedure 4 to try again. If the "Cal Error" is still displayed in the end, the unit needs to be repaired in factory, otherwise, Zeroing Calibration has succeeded, go to next step.
7. Turn off the gas flow and remove it.

### 3.10 Menu “3\_Span Calibration”



Span Calibration Flow Chart

#### 3.10.1 Span Calibration Procedure

1. Connect tubing to IR-FREON-D
  - For Diffusion Version: Connect the cal gas supply tubing to the fitting on the right side of enclosure
  - For Pump-through Version: Connect the cal gas supply tubing to the push-in fitting on the bottom side of enclosure
2. Turn on the gas flow and press Key [YES] to display current reading



This screen is displaying the current reading and asking if you want to perform Span Calibration.

3. Waiting for about 3 minutes or till the reading is stable.
4. Press Key [YES] to perform Span Calibration.
5. During Span Calibration, the LCD will display the digital pot positions and calibration statuses. It will take about 1 minute to perform Span Calibration, then the span calibration data is saved and LCD displays “Accepted”.
6. If the LCD displays “Cal Error” that means something is wrong in the procedure, repeat procedure 4 to try again. If the “Cal Error” is still displayed in the end, the unit needs to be repaired in factory, otherwise, Span Calibration has succeeded, go to next step.
7. Turn off the gas flow and remove it.



### 3.13 Menu “6\_Relay Database”

#### 3.13.1 Relay Configurations

<p><b>Enabled:</b></p>	<p>Each relay may be individually set to be enabled or disabled. If it's disabled, the relay is always de-actuate no matter what's the current gas concentration.</p> <p><b>Default is Enabled.</b></p>
<p><b>Normally De-energized:</b></p>	<p>Each relay may be individually set to be Normally Energized or Normally De-energized.</p> <p><b>Default is De-energized.</b></p>
<p><b>Latching:</b></p>	<p>Each relay may be set to latch in Actuate status until acknowledged by a front-panel action. Hold the button [ESC] for 3 seconds to release latched relays.</p> <p><b>Default is Non-Latching.</b></p>
<p><b>Action On:</b></p> <p><b>Action Off:</b></p>	<p><i><b>If Action On is greater than or equal to Action Off (Window=OFF):</b></i></p> <p>Action On: Set the concentration at or above which the relay will actuate.</p> <p>Action Off: Set the concentration at or below which the relay will de-actuate.</p> <p><i><b>If Action On is less than Action Off (Window=OFF):</b></i></p> <p>Action On: Set the concentration below that the relay will actuate.</p> <p>Action Off: Set the concentration above that the relay will de-actuate.</p> <p><b>Defaults:</b></p> <ul style="list-style-type: none"> <li>• <b>Relay1 Action On / Off: 500 / 480 ppm</b></li> <li>• <b>Relay2 Action On / Off: 750 / 720 ppm</b></li> <li>• <b>Relay3 Action On / Off: 1000 / 950 ppm</b></li> </ul> <p><b>Note: Based on the MSDS sheets for all refrigerants, with the exception of R123, the permissible 8-hour exposure limit is 1000ppm. QEL does not recommend any setpoints below 250ppm to prevent false alarms from such things as large temperature or pressure changes.</b></p>

<p><b>ON Delay:</b></p>	<p>“Delay on Actuation” or “Delay on Make”. For each relay a separate time delay may be set from 0 to 990 seconds before an alarm condition will cause the relay to actuate.</p> <p><b>Default is 30 seconds.</b></p>
<p><b>OFF Delay:</b></p>	<p>“Delay on De-Actuation” or “Delay on Break”. For each relay a separate time delay may be set from 0 to 990 seconds before a return to a non-alarming signal condition will cause the relay to de-actuate.</p> <p><b>Default is 30 seconds.</b></p>
<p><b>Fault:</b></p>	<p>Set to ON for actuating the relay if the unit reports any Faults.</p> <p><b>Default is ON.</b></p>
<p><b>Window:</b></p>	<p>When it’s set to <b>ON</b>, if the concentration is between <b>Action ON</b> and <b>Action Off</b>, the relay will be de-actuated; if the concentration is out of the windows (Action ON and Action Off), the relay will be actuated.</p> <p><b>Default is OFF.</b></p>

3.13.2 Relay Database Flow Chart

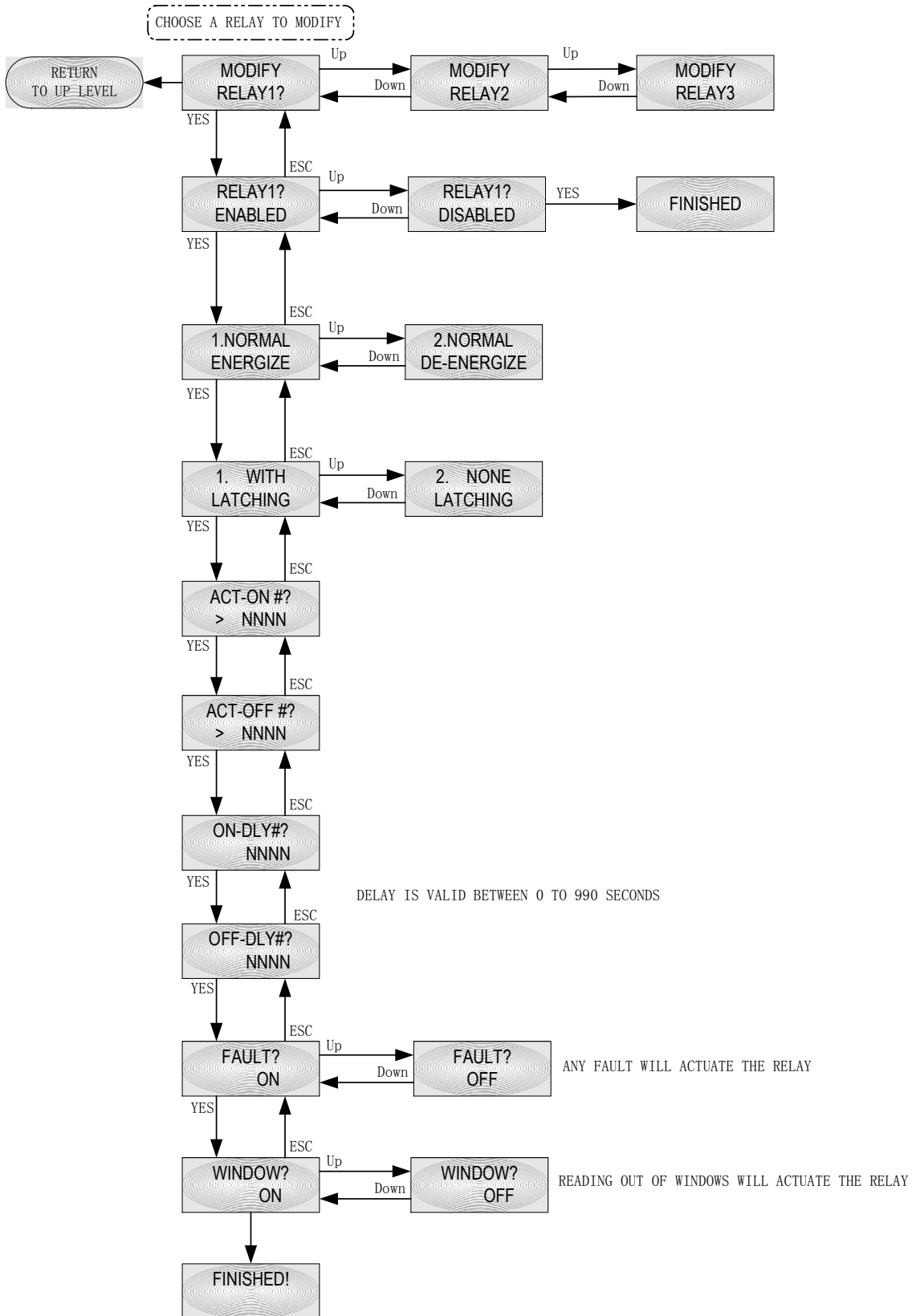

### 3.14 Menu “7\_A-Out Database”

The Analog Database setup is almost identical to that of the relays.

IR-Freon-D will compare the concentration at 4mA and the concentration at 20mA, you may assign a larger concentration for 4.0 milliamps than for 20 milliamps; the IR-FREON-D will still stretch a straight line signal between the two points and then convert the current gas reading to analog output.

**Note: The Analog Output can not be disabled.**

**Note: When the sensor has fault, it will output 2.5mA to indicate fault status.**

<b>Conc@4mA:</b>	Input the gas concentration at which the 4mA is output.  <b>Default is 0 ppm.</b>
<b>Conc@20mA:</b>	Input the gas concentration at which the 20mA is output.  <b>Default is 1000 ppm.</b>

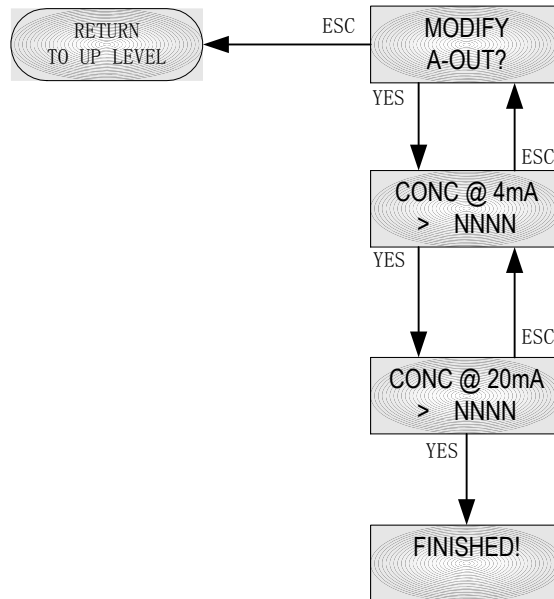

### **3.15 Menu “8\_Buzzer Database”**

The buzzer setup is almost identical to that of the relays, except that there are three buzzer options.

- Buzzer 1: Double-tap Intermittent
- Buzzer 2: Intermittent 50% duty cycle
- Buzzer 3: Continuous

Buzzer 3 has highest priority and Buzzer 1 has lowest priority.

The menus are identical to those for the Relay Database. For Relay Database detail and flow chart, please refer 3.13 Menu “6\_Relay Database” on page 24.

### **3.16 Menu “9\_Output Disable”**

This function is for calibration, system testing etc. When Output is disabled, the relay, buzzer and analog output, etc., statuses will freeze in whatever state they are already in.

**Default is “Output Enabled” when the unit is powered up.**

### **3.17 Menu “10\_Simu Disable”**

Simulation Mode is to assist in testing the installation before commissioning. When the simulation is enabled, the unit will not detect gas concentration, it will display the simulating value and use it to calculate the statuses of relays and buzzer, as well as 4-20mA analog output. This feature is available for evaluating the user settings and testing the installation (e.g.: the travel of the valve, fan speed, relay set points, etc. can be verified.)

Any concentration between 0ppm and 9999ppm can be simulated.

**Default is “Simu Disabled” when the unit is powered up.**

## **4. MODBUS Protocol Supported By IR-FREON-D**

For ModBus protocol, please contact QEL.

## 5. Maintenance

### 5.1 DVM Connection for 4-20mA measurement

- IR-FREON-D is Offline of the 4-20mA loop:
  - Switch DVM to measure DC current, plug the probe “-“ into GND and plug the probe “+” into SIG- on the Display Board.
- IR-FREON-D is Online of the 4-20mA loop:
  - Switch DVM to measure DC current, plug the probe “-“ into SIG - and plug the probe “+” into SIG + on the Display Board.

### 5.2 4mA and 20mA Output Calibration

These values are established during factory 4-20mA output calibrations and should not require recalibration in the field. Do not attempt to modify these settings in the field.

Changing these values will change the analog output signal scale.

- Entry [Menu]-->[System Setting]
- Choose [4mA CAL]:
  1. Press Key [YES] to output 4mA signal
  2. Connect DVM to the unit as described above
  3. Press Key [Up] and Key [Down] to adjust the current to 4.00mA to 4.05mA
  4. Press Key [YES] again, then the settings will be accepted and saved
- Choose [20mA CAL]:
  1. Press Key [YES] to output 20mA signal
  2. Connect DVM to the unit as described above
  3. Press Key [Up] and Key [Down] to adjust the current to 20.00 to 20.05mA
  4. Press Key [YES] again, then the settings will be accepted and saved

## 6. Troubleshooting

This troubleshooting guide is intended as an aid in identifying the cause of unexpected behavior and determining whether the behavior is due to normal operation or an internal or external problem.

SYMPTOMS	PROBABLE CAUSE	SUGGESTED SOLUTION
RS-485 RX LED or TX LED constantly ON	<ul style="list-style-type: none"> <li>• RS-485 bus connection has problem</li> <li>• RS-485 Driver U7 is damaged</li> <li>• Controller side RS-485 Driver has problem</li> </ul>	<ul style="list-style-type: none"> <li>• Disconnect the Cable to isolate the problem</li> <li>• Replace U7 IC on display board</li> <li>• Replace RS-485 Driver in Controller</li> </ul>
In Warm Up Mode too long	<ul style="list-style-type: none"> <li>• In Warming up process</li> <li>• Temperature sensor broken</li> <li>• Heater is broken</li> </ul>	<ul style="list-style-type: none"> <li>• Wait for the block to warm up</li> <li>• Check IR Block Assembly</li> <li>• Check IR Block Assembly</li> </ul>
Error Report [PH-DIRTY]  [LP-SHORT] / [LP-OPEN] [CAL-ERR]	<ul style="list-style-type: none"> <li>• IR Source or Lamp Dirty</li> <li>• Gas Sample Cell Dirty</li> <li>• Signal Fault</li> <li>• Drift too much</li> <li>• Lamp Short/Open</li> <li>• Calibrating Error</li> <li>• Other Error</li> </ul>	<ul style="list-style-type: none"> <li>• Return to Factory</li> <li>• Return to Factory</li> <li>• Return to Factory</li> <li>• Re-zeroing calibration</li> <li>• Check IR Block Assembly</li> <li>• Recalibration or Cycle Power or Check Gas Flow or Use different calibration gas or Replace weak IR Source Assembly or Replace Broken IR Detector Assembly</li> <li>• Return to Factory</li> </ul>
IR Source LED is constant ON or OFF, not blinking	<ul style="list-style-type: none"> <li>• Main Board has problem</li> <li>• Heater is short/Open</li> </ul>	<ul style="list-style-type: none"> <li>• Check Firmware and Driver</li> <li>• Check IR Block Assembly</li> </ul>
Reading abnormally high or low or jumping around randomly	<ul style="list-style-type: none"> <li>• Dirty Sensor Block</li> <li>• Excessive moisture</li> <li>• Weak IR Source</li> <li>• Temperature Sensor Loose</li> </ul>	<ul style="list-style-type: none"> <li>• Return to Factory</li> <li>• Add filter to gas inlet</li> <li>• Replace IR Source Assembly</li> <li>• Check IR Block Assembly</li> </ul>

## WARRANTY STATEMENT

The information contained in this manual is based upon data considered accurate; however, no warranty is expressed or implied regarding the accuracy of this data. All QEL equipment is warranted against defects in material and workmanship for a period of two years from date of shipment with the following exceptions:

Electrochemical Sensors (Toxic)	Six Months
Catalytic Sensors (Combustible)	One Year

During the warranty period we will repair or replace, at our discretion, any components or complete units that prove, in our opinion, to be defective. We are not liable for consequential or incidental damage to auxiliary interfaced equipment.

A returned material authorization number should be obtained from the factory prior to returning any goods. All return shipments must be shipped freight prepaid and a copy of the maintenance records should accompany the unit concerned.

Warranty should be considered F.O.B. the factory. Labour and travel time are chargeable for any field site visits required for warranty work.

### LIMITED LIABILITY

All QEL systems shall be installed by a qualified technician/electrician and maintained in strict accordance with data provided for individual systems in the form of installation/maintenance manuals. QEL assumes no responsibility for improper installation, maintenance, etc., and stresses the importance of reading all manuals. QEL shall not be responsible for any liability arising from auxiliary interfaced equipment nor any damage resulting from the installation or operation of this equipment.

QEL's total liability is contained as above with no other liability expressed or implied, as the purchaser is entirely responsible for installation and maintenance of systems.

This warranty is in lieu of all other warranties, expressed or implied, and no representative or person is authorized to represent or assume for QEL any liability in connection with the sales of our products other than that set forth herein.

NOTE: Due to on-going product development, QEL reserves the right to change specifications without notice and will assume no responsibility for any costs as a result of modifications.

For further information or assistance, contact:

### **QUATROSENSE ENVIRONMENTAL LTD.**

5935 Ottawa Street, PO Box 749

Richmond, Ontario

K0A 2Z0

Tel: (613) 838-4005

Fax: (613) 838-4018

Email: [QEL@QELsafety.com](mailto:QEL@QELsafety.com)

Web: [www.QELsafety.com](http://www.QELsafety.com)