

**CTS-M17
METHANE/PROPANE
TRANSMITTER/SENSOR**

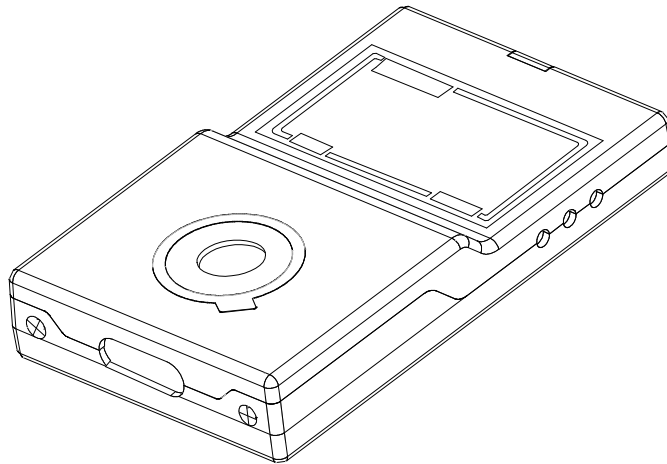

**INSTALLATION
OPERATION AND MAINTENANCE
MANUAL**

QUATROSENSE ENVIRONMENTAL LTD.
5935 OTTAWA STREET, PO BOX 749 Richmond, ONTARIO, CANADA, K0A 2Z0
PHONE: (613) 838-4005 FAX: (613) 838-4018
Web: www.QELsafety.com Email: QEL@QELsafety.com

CTS-M17 Configuration

Note: Defaults are used unless otherwise indicated under "User".

No.	Setting	Default	User
1	Sensor Type/Gas Sensed	NAP-55A/Methane	
2	Signal 20 mA	100 %LEL	
3	Signal 4 mA	0 %LEL	
4	Password	0017	
5*	Relay 1	Enabled	
6	Relay 1 Set point (Actuation)	20 %LEL	
7	Relay 1 Release Point (De-Actuation)	15 %LEL	
8	Relay 1 Actuation Delay	0 Minutes	
9	Relay 1 De-Actuation Delay	0 Minutes	
10*	Relay 2	Enabled	
11	Relay 2 Set point (Actuation)	40 %LEL	
12	Relay 2 Release Point (De-Actuation)	35 %LEL	
13	Relay 2 Actuation Delay	0 Minutes	
14	Relay 2 De-Actuation Delay	0 Minutes	
15	Communication Protocol	Optomux	
16	Digital Address	0001	
17	Baud rate	4800	

***Note:** Relay set points are included in the software; however, relays are optional.

Table of Contents

1. PRINCIPLE OF OPERATION	4
1.1 Display	4
1.2 Keypad and Function Configuration	4
1.3 Password	5
1.4 Output Signals.....	5
1.5 Meter Jacks	5
1.6 Signal Range	6
1.7 Optional Relay Package.....	6
1.8 Default Conditions.....	6
1.9 Sensing and Calibration	6
1.9.1 Calibration.....	6
1.9.2 Implications for Troubleshooting.....	7
2. FUNCTION AND CONFIGURATION	7
2.1 Menu Structure and Use.....	7
2.2 Configuration and Calibration.....	8
2.3 Hardware Configuration	16
2.3.1 Output Signals	16
2.3.2 RS-485 End-of-Line Wiring and Termination.....	16
2.4 Gas Calibration	16
2.4.1 Equipment Required.....	16
2.4.2 Calibration Procedure.....	17
2.4.3 Calibration Errors.....	17
3. FAULTS	17
3.1 Self-check Faults.....	17
3.2 Fault Code Matrix	19
3.3 Hardware Fault Diagnostics	19
4. WIRING AND CONNECTIONS.....	20
4.1 Power and Signaling	20
4.2 Relay Wiring	23
4.3 RS-485 Wiring: Shielding and Grounding	24
WARRANTY STATEMENT	25

List Of Figures

Figure 1 - CTS-M17 Internal View and Features.....	4
Figure 2 - Output Signal Select Jumper (JP1).....	5
Figure 3 - Output Signal Select Jumper (JP1).....	16
Figure 4 - RS-485 End-of-Line Termination (JP2)	16
Figure 5 - Calibration Gas Bayonet Adapter	17
Figure 6 - Wiring Terminations (TB1, TB2, TB3, TB4 and TB5)	20
Figure 7 - 24VAC Floating Supply	20
Figure 8 - 24VAC Supply with Common Ground	21
Figure 9 - 24VAC Supply with Separate Grounds.....	21
Figure 10 - 24VDC Supply with Common Ground.....	22
Figure 11 - 24VDC Supply with Separate Grounds	22
Figure 12 - 24VDC Floating Supply	23
Figure 13 - Relay Terminations (TB4 and TB5).....	23
Figure 14 - RS-485 Terminations (TB2 and JP2).....	24

The keypad is a set of three push buttons recessed along the upper right side of the enclosure. It is not necessary to open the cover for use of the keypad. Access to the menus is password restricted. Press any key for 3 seconds to enter the menus (see below for details).

1.3 Password

The factory preset default password is 0017. The password can be changed.

IMPORTANT: RECORD PASSWORD IN A SECURE PLACE. If the password is lost, the unit must be returned to QEL to be reset.

1.4 Output Signals

Options are 4-20 mA or 2-10 VDC linear. Choose the option by moving the jumper on JP1. On over range concentrations the signal can exceed the range slightly.

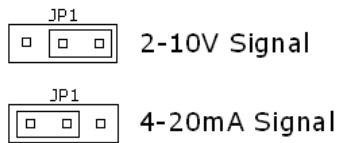

Figure 2 - Output Signal Select Jumper (JP1)

IMPORTANT: Voltage monitoring should be into a monitor with at least 50,000 Ohms input impedance. Voltage monitoring is not recommended over long distances, as these signals are more susceptible to induced noise than current signals

1.5 Meter Jacks

Test pads, accepting standard test probes are provided on the circuit card. These are labeled SIGA, SIGB and COMMON.

To test the analog output signal, measure:

- SIGA to COMMON shorts to internal ground.
- SIGA to SIGB without interrupting signal to monitor.

To Test voltage signals measure:

- SIGB to COMMON.

1.6 Signal Range

The default gas range for the 4-20 mA signal is:

0 – 100 %LEL max = 500 %LEL

This range is adjustable. Both the 4 mA level and the 20 mA level can be reassigned through the menu system. Note that this adjustment does not change the measurement resolution.

IMPORTANT: The Signal Range is the applied range of the 4-20 mA signal. The Display Range is independent of the signal range.

1.7 Optional Relay Package

Two relays can be supplied; single pole double throw (SPDT; Form C) 1 Amp. Dry contacts only. Configuration allows set point adjustment for actuation point, dead-band, and delays, increasing or decreasing concentrations. The relay settings have the same range as the display, and are independent of Analog Signal Range.

1.8 Default Conditions

Default conditions are those conditions, which occur:

- During the one minute wait state on Power On.
- In Fault status.
- In menu tree.

In these situations the following conditions hold:

- Signal set at 4.0 mA (or 2 Volts on Voltage Output mode)
- Relays set to non-energized.
- Digital communication show 0 %LEL; no alarm status and 4 mA equivalent signal.

1.9 Sensing and Calibration

Sensor type: Catalytic bead

1.9.1 Calibration

The sensor shows a linear response to gas and therefore the unit is straightforward to calibrate. Two gases are needed for calibration: Zero gas (clean air) and an appropriate span gas. Adjustment is by two potentiometers on the circuit board.

1.9.2 Implications for Troubleshooting

The microprocessor will detect various component faults and out-of-range conditions, and subsequently drop the output signal to 0.0 mA. When a fault is detected, both relays will be deactivated as well. However, it cannot detect simple out of calibration conditions, which can only be detected by applying a gas standard.

2. Function and Configuration

2.1 Menu Structure and Use

Note: While the keypad functions are available without opening the case. It is necessary to open the case to apply the calibration gases. The 'keypad' switches are located in the upper right side of the enclosure (See Figure 1).

Display: The display is 2 line by 8 character alphanumeric liquid crystal. The top line contains the feature name and the second contains the variable.

Keypad: The keypad consists of three (3) pushbutton switches.

S1	Scroll Up
S2	Scroll Down
S3	Enter/Accept

Display at Turn-On:

The display shows the following for about 2 seconds:

QEL M-17
Vx.xx Ry

Where: x.xx = the Software Version
 y = the Software Revision

Followed for about 2 seconds by:

NAP-55A
Vx.xx Ry

Where: NAP-55A = Sensor Type
 x.xx = the Sensor Algorithm Version
 y = the Sensor Algorithm Revision

Display in Operation: The display shows

--GAS--
xxx %LEL

where --GAS-- is the selected target gas, and xxx the concentration of the gas.

Note: The unit features a warm-up function to prevent false alarms while the sensor is warming up. Warm-up is activated when the unit is powered up initially. During warm-up, "----" will be shown in the bottom line of the display in place of the gas concentration. It is not possible to enter the menu system during warm-up. Sensor warm-up duration is from one minute to several minutes, depending on gas and/or sensor type.

Note: Should the concentration equal or drop below -5% LEL, the unit will flash "CALIBR" on display line 2 every 8 seconds.

Menu Activation: Press and hold any key for 3 seconds to enter the menu tree.

Menu Scrolling: Use the scroll buttons to scroll up and down through the menu tree.

Data Entry Mode: Access the data entry mode by pressing S3 (Enter) while displaying any adjustable configuration setting. This mode is indicated by an * (asterisk) at the right of the variable, and indicates that the variable may be changed by scrolling. Press S3 (Accept) to save result and return to menu tree. While in data entry mode, the Up and Down keys perform an automatic key repeat while the key is held in.

Password: The first item on entering the menu tree is a password request. The display shows 0000, the default password is 0017. The * appears, indicating that a number can be scrolled to the password, and then entered with S3. The password can be changed by the user (see below).

Fault: In case of faults, the display will read FAULT and a fault code in the bottom LCD line (see below). The analog output signal will drop to 0 mA (or 0V).

See section 3 below for more information on faults.

2.2 Configuration and Calibration

Note: The user has control of all variables, including calibration gas concentrations, alarm settings and signal range (both 4 mA and 20 mA) assignments. It is important to note that these must be chosen carefully with regard to calibration. Calibration is done with potentiometers on the circuit card, not through the menu system, therefore it is possible to perform the adjustments without the menu system; however, the menus do offer **increased display resolution**, and **disabling of relay actuation**. Please contact QEL customer support for non-standard adjustments. It is advised to make one or two adjustments at a time, unless you are very familiar with the product. Remember to save your settings when exiting the menu system.

1. **Press any key for 3 seconds to enter menu system**
2. **Password Control**

PASSWORD

0000 *

Press up/down to choose select password and accept with S3.

3. Factory Settings Sub-menu Branch

FACTORY Settings

This function is for factory setup and test only. Do not change these settings, unless instructed to do by QEL service or support staff.

4. Relay 1 Sub-menu Branch

Note: Per CSA Standard C22.2 No 152, *Combustible Gas Detection Instruments*, **relay alarm settings are limited to a maximum of 60% LEL.**

RELAY 1 Settings

Press Enter to proceed to the Relay 1 Settings sub-menu (press down/up to skip Relay 1 Settings and go to next/previous menu item or sub-menu).

4.1 Relay Mode

RELAY Enable

Press Enter to change. "*" Indicates that the scroll buttons can be used to toggle between Enable, Disable or Latching. Press Accept when done.

Note that this disables the physical relay, but not the set point. Set-point actuation status will still be transmitted on the digital communications link if queried.

When the "Latching" option is selected, the relay will not de-actuate unless it is cancelled by pressing one of the keyboard buttons. The relay will only reset if the alarm situation has dissipated.

Enable is the default.

Press the Down button to continue through the Relay 1 Settings branch. Press Up to return to the Main Menu (and Relay 1 Settings sub-menu branch).

4.2 Actuation Set Point

ACTUATE

020 %LEL

Choose the concentration of Gas in %LEL at which the relay will actuate (energize). Minimum = 5 %LEL. Maximum = 60 %LEL in 5 %LEL increments.

Default = 20 %LEL

Up/Down scrolls up/down in the Relay 1 Settings branch.

4.3 De-Actuation Set point

DEACT 015 %LEL

Choose the concentration of the gas in %LEL at which the relay will de-actuate (de-energize). Minimum = 5 %LEL. Maximum = 60 %LEL in 5 %LEL increments.

Default = 15 %LEL.

Note: If the De-actuation set point is set at a higher concentration than the Actuation set point, then the set point function reverses and actuates on decreasing concentrations.

Note: The software will not allow the user to set Actuation = De-actuation.

4.4 Actuation Delay

ACT-TIME 00 min

Adjust the amount of time delayed before the relay is actuated after the Actuation set point is reached. A maximum of 60 minutes is possible, adjustable in 5-minute increments.

Default is 0000.

4.5 De-Actuation Delay

DEACTIME 00 min

Adjust the amount of time delayed before the relay is released after the De-Actuation set point is reached. A maximum of 60 minutes is possible, adjustable in 5-minute increments.

Default is 0000.

The Up key scrolls back up the Relay 1 Settings sub-menu branch. The Down key leaves the Relay 1 Settings sub-menu branch and returns to the Relay 1 Settings main menu item.

4.6 Buzzer Mode

BUZZER Disable

The internal buzzer can be activated together with Relay 1 (and/or Relay 2 – see Relay 2 sub-menu branch below) if 'Enable' is selected. Pressing any of the keys during normal operation silences the buzzer. Selecting 'Disable' in this sub-menu only disables the buzzer activation for Relay 1. Buzzer operation respective to Relay 2 is set in the 'Relay 2 Settings' sub-menu.

Note: If the buzzer is enabled for any of, or both the relays, the first key press will silence the buzzer (buzzer acknowledge) and a second key press is needed if any, or both of the relays is set for 'Latching' mode. Refer to 3.1 above.

To configure the buzzer for Relay 2 operation, go the 'Relay 2 Settings' sub-menu.

Default is Disabled.

5. Relay 2 Sub-menu Branch

Note: Per CSA Standard C22.2 No 152, *Combustible Gas Detection Instruments*, **relay alarm settings are limited to a maximum of 60% LEL.**

RELAY 2 Settings

Press Enter to access the settings. The sub-menu structure is the same as for Relay 1 Settings. Defaults are as follows:

5.1 Relay Mode

Enabled

5.2 Actuation Set point

Minimum = 5 %LEL. Maximum = 60 %LEL in 5 %LEL increments.
Default = 40 %LEL

5.3. De-Actuation Set Point

Minimum = 5 %LEL. Maximum = 60 %LEL in 5 %LEL increments.
Default = 35 %LEL.

6. Range Adjustment – 4mA

CONC 4mA **000 %LEL**

This feature allows adjustment of the 4 mA point to non-zero gas concentrations. The display will always read as low as 0000 %LEL, but the concentration corresponding to 4 mA changes.

Maximum: 500 %LEL (see note 3 below)
Minimum: 0 %LEL

Note 1: An inverted response at the signal output can be achieved by setting CONC4MA higher than CONC20MA.

Note 2: Changing the range in this fashion does not enhance the gas measurement accuracy. e.g.: If there is an error of 1 %LEL, it will still be an error of 1 %LEL even if the range is reduced.

Note 3: Even though the 4mA point can be adjusted beyond 100%LEL, the product can only measure accurately to just over 100%LEL, due to the response of the sensor. The range up to 500%LEL is only provided for flexibility in the installation.

IMPORTANT: Do *not* set CONC4MA and CONC20MA points ***closer than 10 %LEL***. If the unit finds these points closer than 10%LEL on menu system exit, the higher point will be ***automatically*** adjusted until a minimum difference of 10%LEL is present.

7. Range Adjustment – 20mA

CONC20mA **100 %LEL**

This feature allows adjustment of the 20 mA point to different gas concentrations.

Note: This setting only affects the concentration corresponding to 20 mA and not the range displayed on the LCD.

Maximum: 500 %LEL (see note 3 below)
Minimum: 0 %LEL

Note 1: An inverted response at the signal output can be achieved by setting CONC4MA higher than CONC20MA.

Note 2: Changing the range in this fashion does not enhance the gas measurement accuracy (e.g.: If there is an error of 1 %LEL, it will still be an error of 1 %LEL even if the range is reduced).

Note 3: Even though the 20mA point can be adjusted beyond 100%LEL, the product can only measure accurately to just over 100%LEL, due to the response of the sensor. The range up to 500%LEL is only provided for flexibility in the installation.

IMPORTANT: Do *not* set CONC4MA and CONC20MA points ***closer than 10 %LEL***. If the unit finds these points closer than 10%LEL on menu system exit, the higher point will be ***automatically*** adjusted until a minimum difference of 10%LEL is present.

8. Gas Type Selection

GAS TYPE Methane

Choose GAS TYPE from:

Methane
Butane
Ethanol
Genl LEL (General %LEL)
Propane
Hydrogen

Factory default is Methane.

Note: When changing the gas type, the unit must be **re-calibrated** to the selected gas type and concentration.

9. Auto-zero

When the Auto-zero function is enabled the unit will perform an automatic zero calibration of it's reading. It does this by maintaining a record of the lowest reading observed in the last 8 days and then assigning that as the new zero gas base line. This is subject to overriding measures of sensor failure. In addition, if the drift has been more than negative 5% of the LEL, then the unit will flash "AUTOZERO"

AUTOZERO Enable

This menu item has options:

Enable
Disable
Clear

Clear resets the Auto-zero setting. This should be done after every calibration.

Note: Selecting "Clear" will **clear** the 8-day auto-zero timer **and automatically enable auto-zero**. If you want auto-zero **disabled** after clearing the auto-zero timer, go back into AUTOZERO and select "**Disable**".

10. Calibration

Calibration is done with potentiometers on the circuit card, not through the menu system, and so it is possible to perform the adjustments without the menu system; however, the menus do offer increased **display resolution**, and **disabling of output actuation**.

CALIBR **010.5 %**

Entering this menu item only displays the concentration with 0.1% resolution for more accurate calibration. Reading is in %LEL, even though only % is displayed.

Calibration Procedure:

Response of this sensor to gas is quite rapid, and the signal should be adequately stable for adjustment in less than one minute. It is best to allow one hour warm-up and stabilization time before calibrating.

Apply zero gas (clean air) and adjust the Zero potentiometer until the display reading is 00.0 % (Remember that the 4-20 mA signal may be set to a different range).

Apply an appropriate span gas (e.g. 2.5% CH₄ = 50% LEL CH₄), and adjust the Gain potentiometer to get the correct reading on the display.

Press Up/Down to go to the next/previous menu item.

Remember: If the Auto-zero is enabled, you must perform the AUTOZERO | Clear function to reset the Auto-zero memory.

11. Communications Protocol

PROTOCOL **Optomux**

The **Optomux** protocol (default) communicates with QEL's M-Controller. The **B4000** protocol communicates with QEL's QDC-4000 monitor.

Press Enter and Up/Down to select the desired protocol.

12. Digital Address

ADDRESS
0001

Allows changes to the digital communications address for the M-17 transmitter.

Note: The new address is available immediately after it is accepted at this point, and the unit will respond to only this address when queried even though you are still inside the main menu tree. If you abort the main menu tree (see below) then the address will revert to the previous address.

Maximum: 256

Note: If the B4000 protocol was selected (above), all communications addresses higher than 16 will be folded back to address 16.

13. Baud Rate

BAUDRATE
4800

Default is 4800 Baud.

Options: 1200, 2400, 4800 or 9600 Baud.

14. Password Selection

PASSWORD
0017

Factory default is 0017.

Press Enter and scroll up and down to choose a new password.

RECORD PASSWORD IN A SECURE PLACE.

Note: This item displays the current password, so it is important to keep security in mind when passing this item in the presence of bystanders.

If the password is lost, the unit must be returned to QEL to be reset.

15. Exit Menu Tree

EXIT

Save

Press Enter, an * will appear beside Save. Press Up/Down to choose Save or Abort. Press Enter/Accept to exit.

Note: Choosing Abort will discard all changes made since last entering the menu system, including calibration values.

2.3 Hardware Configuration

2.3.1 Output Signals

Options are 4-20 mA or 2-10 V linear. Choose the option by moving the jumper on JP1. On over-range concentrations the signal can exceed the range slightly.

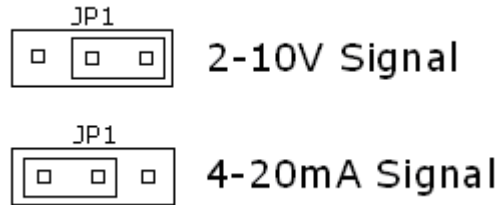

Figure 3 - Output Signal Select Jumper (JP1)

2.3.2 RS-485 End-of-Line Wiring and Termination

RS-485 installations require specialized wiring. A number of manufacturers make cable especially for this wiring standard (EIA-485), (e.g. Belden 9841). This is a twisted, shielded, balanced pair, 24 awg, 120 ohm. In order to prevent signal bounce-back and other distortions, it is necessary to provide a balancing resistor across both ends of the wire. The M-17 supplies this resistor on board, and it is chosen using a jumper at JP2.

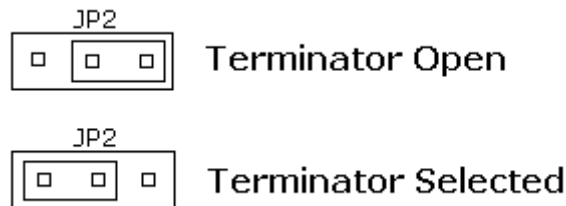

Figure 4 - RS-485 End-of-Line Termination (JP2)

2.4 Gas Calibration

Calibration should not vary significantly over a period of years; however, it is best to perform a verification calibration after installation, and at one-year intervals thereafter. All units are factory calibrated.

2.4.1 Equipment Required

- Zero air, (must contain oxygen).
- Appropriate span gas, typically about 50% LEL
- Pressure and Flow Limiting Regulator(s) **0.4to 0.8 lpm (0.8 to 1.6 scfh)**
- Tubing and bayonet adapter.

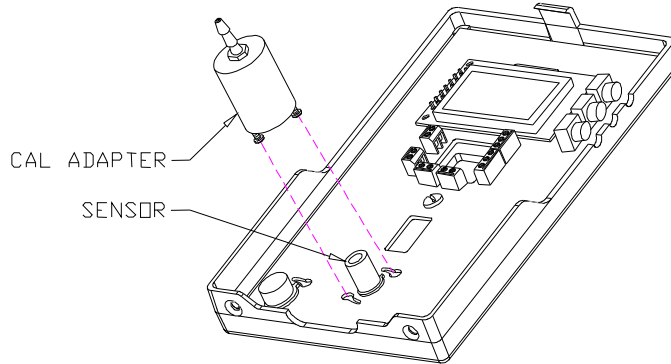

Figure 5 - Calibration Gas Bayonet Adapter

2.4.2 Calibration Procedure

Response of this sensor to gas is quite rapid, and the signal should be adequately stable for adjustment in less than one minute. It is best to allow one hour warm-up and stabilization time before calibrating.

Apply zero gas (clean air) adjust the ZERO (VRES1) potentiometer until the display reading is 00.0. (Remember that the 4-20 mA signal may be set to a different range.)

Apply an appropriate span gas (e.g. 2.5% CH₄ = 50% LEL CH₄), and adjust the GAIN (VRES2) potentiometer to get the correct reading on the display.

Note: If the Auto-zero is enabled, you must perform the AUTOZERO | Clear function to reset the Auto-zero history in memory.

2.4.3 Calibration Errors

If the gas flow was not sufficient, or the bayonet adapter was too loosely applied, the gas concentration in the sensor will stabilize at an incorrect low value. Repeat the calibration procedure if you suspect an incorrect calibration.

3. Faults

3.1 Self-check Faults

The microprocessor monitors a number of operational values for faults, and will display each occurrence for two seconds as follows:

**FAULT
XXX**

Where XXX is a fault code.

The unit will automatically restart and continue normal operation if the fault occurred due to a temporary intrusion (e.g.: Radio frequency interference or water condensation formed due to fast temperature change).

A fault shown repeatedly indicates malfunction of the unit. In such cases the fault code should be recorded and the unit returned for repair.

When a fault is detected, the output is dropped to 0.0 mA and both relays are deactivated.

The only Self Check Faults which can be field addressed are those which refer to problems with the sensor (fault codes 040 through 042 for sensor faults, and 048 through 050 for calibration faults):

- Check that the sensor is installed in the sensor socket correctly.
- Replace sensor. If the fault is removed, then re-calibrate.
- Return unit to Factory.

Note: To calibrate the unit, it may be necessary enter the menu system while the unit is cycling through a fault display, trying to recover normal operation. To enter the menu system in this state, immediately press any key and hold after hearing the turn-on beep, or while seeing the Model ID and Software Revision String ("QEL M-17, V1.00..."). When the password request is seen, you can let go of the key and enter the password in the normal fashion.

3.2 Fault Code Matrix

Fault Code	Description	Action
EEPROM		
008	FLASH EEPROM write time-out.	Return unit to factory for repair if fault persists.
009	Data EEPROM write time-out.	
010	FLASH EEPROM verify error when writing.	
011	Data EEPROM verify error when writing.	
012	Last EEPROM write interrupted, incomplete.	
Analog Output Signal		
032	Driven output higher than monitored output.	Return unit to factory for repair if fault persists.
033	Driven output lower than monitored output.	
034	Voltage output load too large (or mode fault).	
035	Voltage output load driving into unit.	
System		
024	Out of ms timers.	Return unit to factory for repair if fault persists.
025	Out of second timers.	
026	Message queue overflow.	
Sensor		
040	Sensor front-end or heater driver fault.	Check sensor, replace sensor and calibrate. Return unit to factory for repair if fault persists.
041	Pseudo ground level too low.	
042	Pseudo ground level too high.	
Calibration		
048	Concentration too far negative.	Calibrate. Return unit to factory for repair if fault persists.
049	Auto zero drifted too far low.	Calibrate. Return unit to factory for repair if fault persists.
050	Auto zero too far high, never came down from initial value at start of auto-zero cycle.	Calibrate. Return unit to factory for repair if fault persists.
32-bit Mathematics		
056	32-bit scale operation overflow.	Calibrate. Return unit to factory for repair if fault persists.

3.3 Hardware Fault Diagnostics

Fault Condition	Possible Solution
Screen Blank, no Signal	Check Wiring, check fuses.
Distorted MA Signal	Output jumper set to voltage.
Voltage signal pinned high	Output jumper set to mA
No mA Signal on AC floating power supply	Check for signal common line. Check for signal operation by using on-board test points
Bad RS-485 Communications for this unit.	Check wiring polarity for A & B lines Check for correct line terminations. Check for correct address.
Bad RS-485 Communications for a multi-drop group.	Check wiring polarity for A & B lines Check for correct line terminations. It is possible for one failed device on a multi-drop line to pull communication down for the whole line. Check for correct addresses.

4. Wiring and Connections

The M-17 has an isolated power supply. This means that the installer may use different grounds (if any) on the power supply input side from those on the output side. Signal return is not electrically connected. This increases the flexibility the installer has in the powering and monitoring the system; however, on the other hand one has to be careful that all grounds are accounted for.

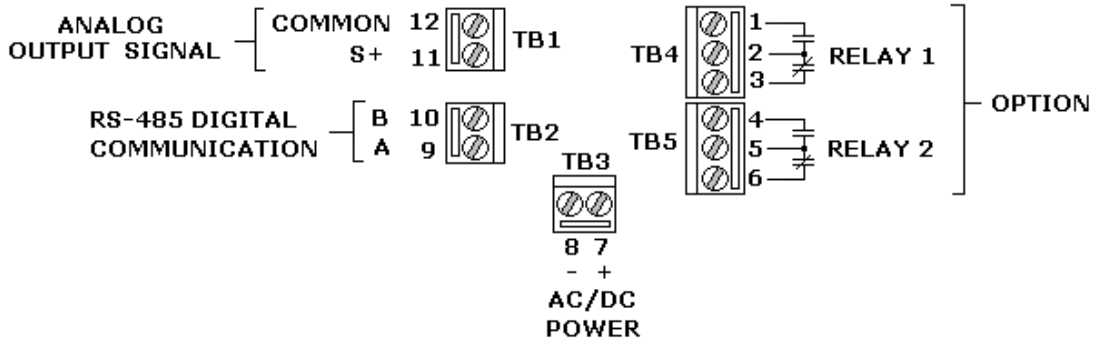

Figure 6 - Wiring Terminations (TB1, TB2, TB3, TB4 and TB5)

4.1 Power and Signaling

The following wiring diagrams list the various connection possibilities with respect to the power supply and the 4 to 20 mA connection.

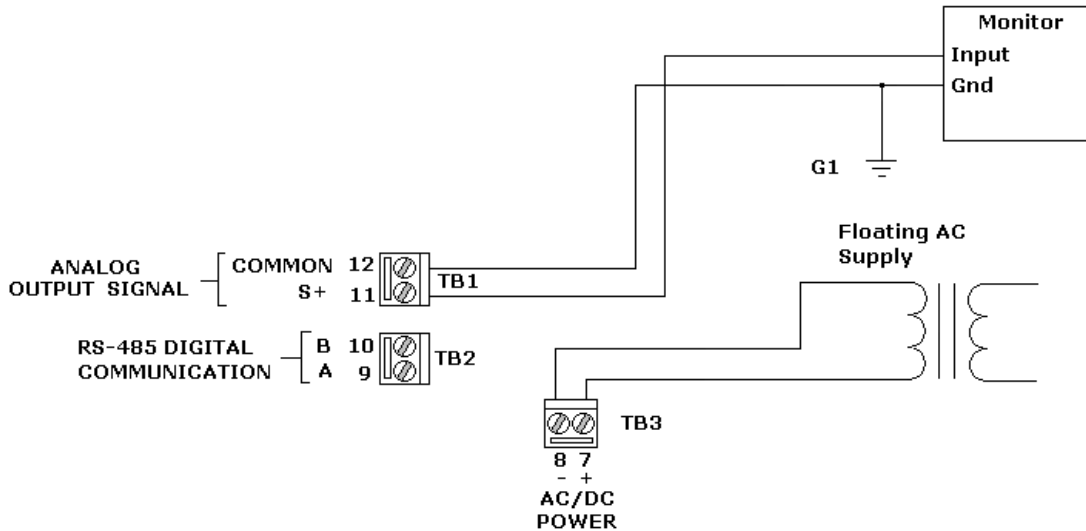

Figure 7 - 24VAC Floating Supply

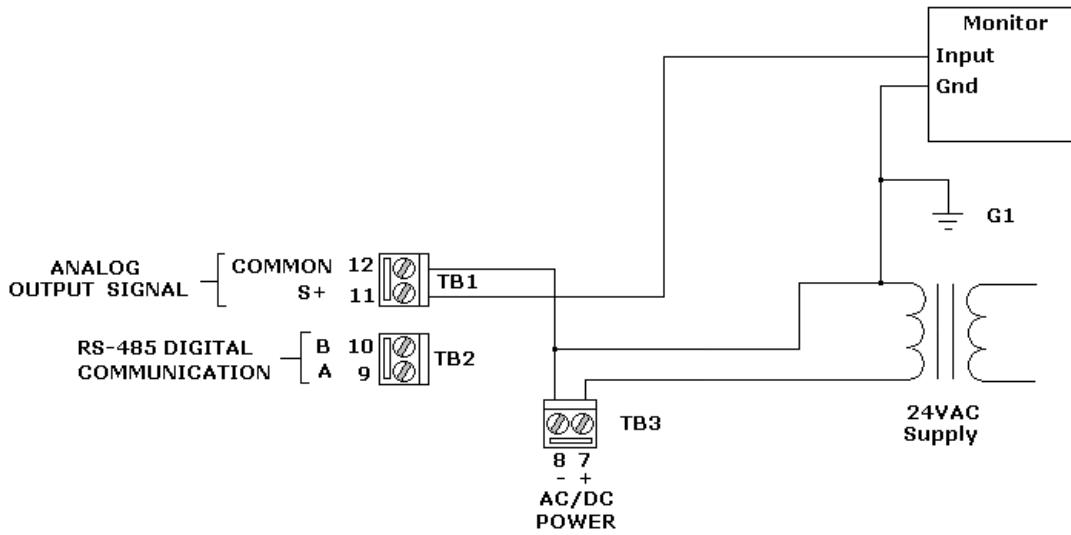

Figure 8 – 24VAC Supply with Common Ground

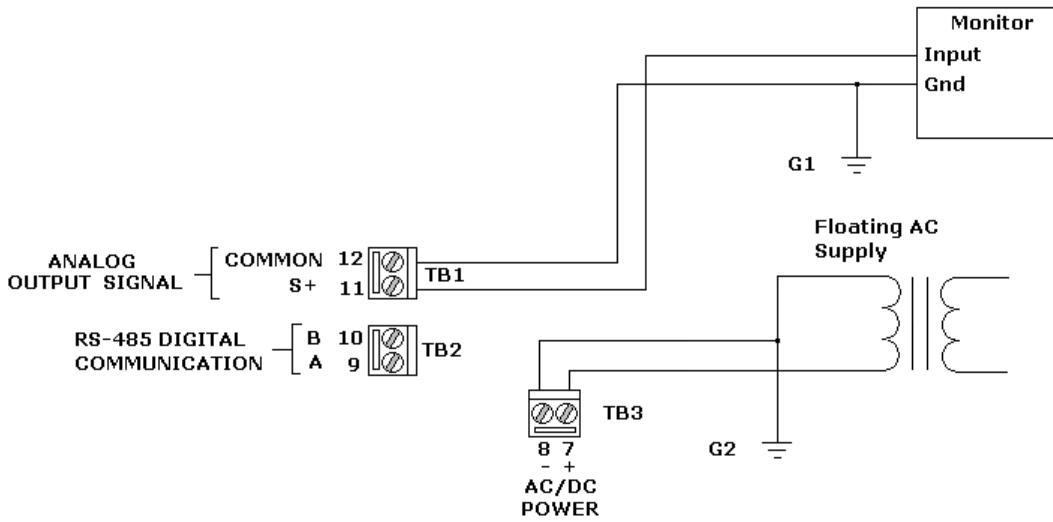

Figure 9 – 24VAC Supply with Separate Grounds

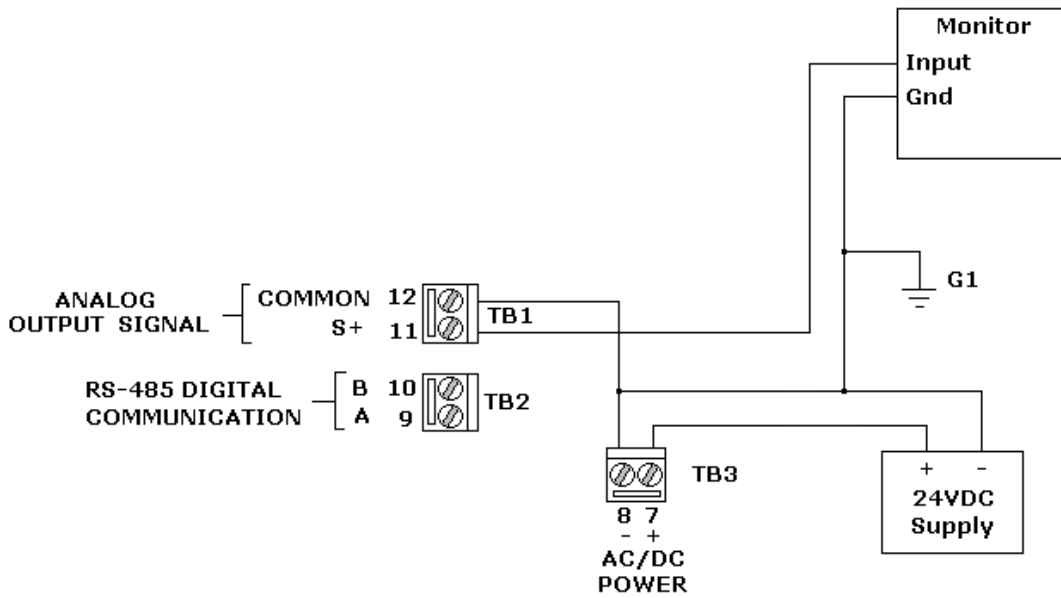

Figure 10 - 24VDC Supply with Common Ground

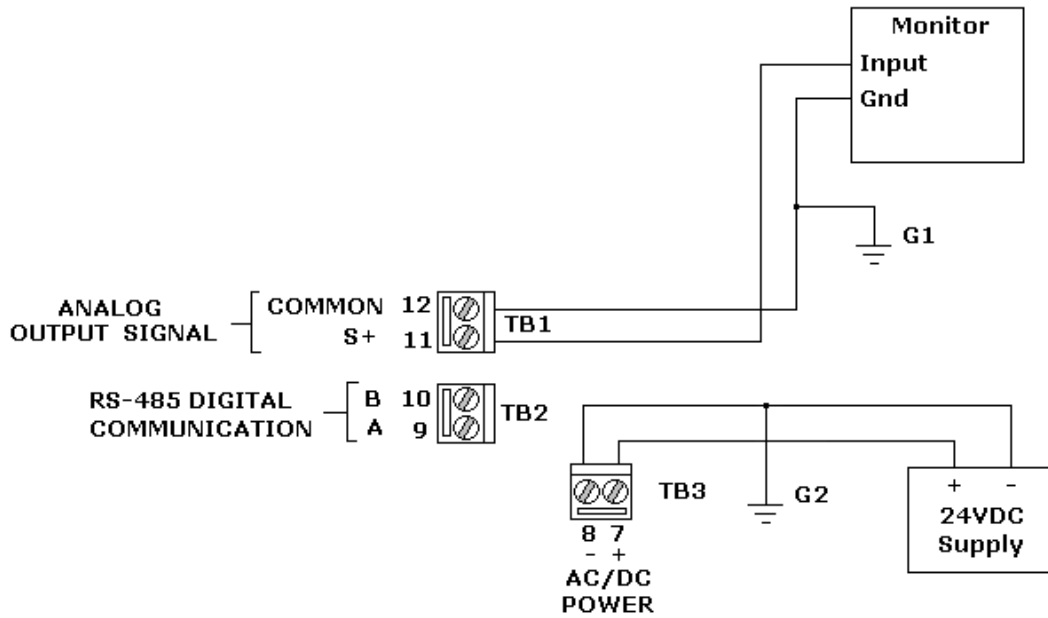

Figure 11 - 24VDC Supply with Separate Grounds

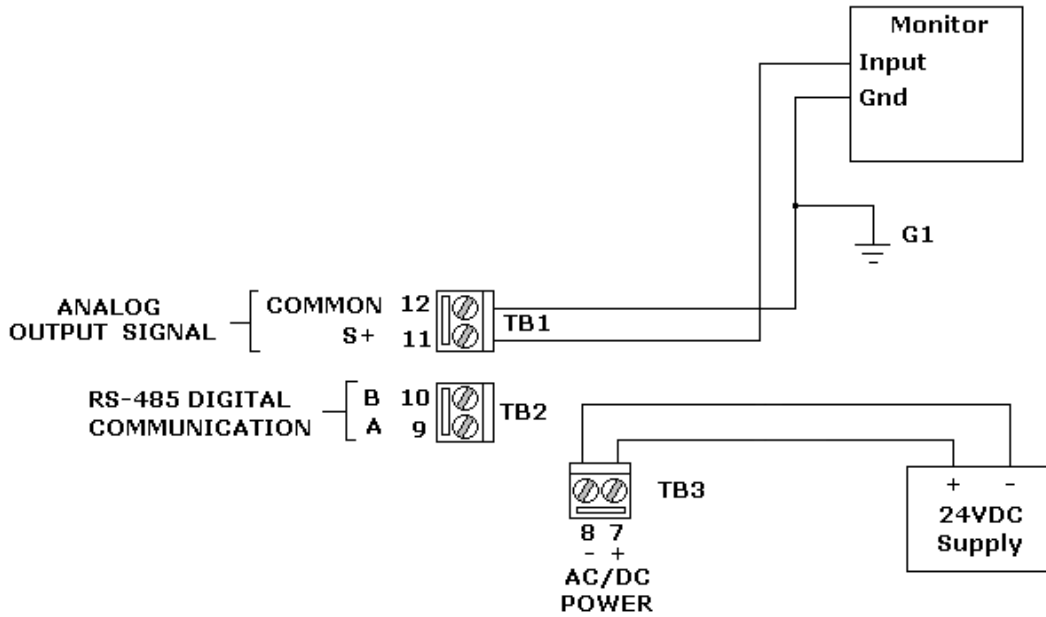

Figure 12 - 24VDC Floating Supply

4.2 Relay Wiring

The relays are Single Pole Double Throw, 1 amp Rated at 120 VAC/24VDC 1 Amp. The relays plus the buzzer are sold as an option package.

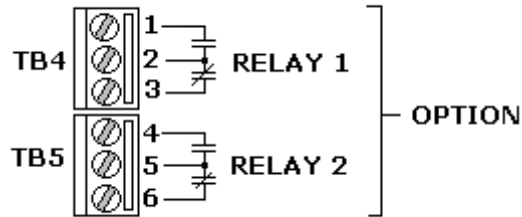

Figure 13 - Relay Terminations (TB4 and TB5)

4.3 RS-485 Wiring: Shielding and Grounding

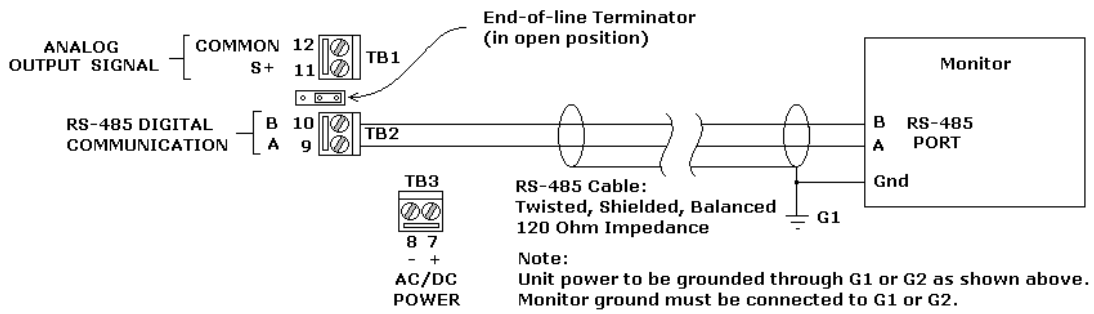

Figure 14 - RS-485 Terminations (TB2 and JP2)

WARRANTY STATEMENT

The information contained in this manual is based upon data considered accurate; however, no warranty is expressed or implied regarding the accuracy of this data. All QEL equipment is warranted against defects in material and workmanship for a period of two years from date of shipment with the following exceptions:

Electrochemical Sensors (Toxic)	Six Months
Catalytic Sensors (Combustible)	One Year

During the warranty period we will repair or replace, at our discretion, any components or complete units that prove, in our opinion, to be defective. We are not liable for consequential or incidental damage to auxiliary interfaced equipment.

A returned material authorization number should be obtained from the factory prior to returning any goods. All return shipments must be shipped freight prepaid and a copy of the maintenance records should accompany the unit concerned.

Warranty should be considered F.O.B. the factory. Labour and travel time are chargeable for any field site visits required for warranty work.

LIMITED LIABILITY

All QEL systems shall be installed by a qualified technician/electrician and maintained in strict accordance with data provided for individual systems in the form of installation/maintenance manuals. QEL assumes no responsibility for improper installation, maintenance, etc., and stresses the importance of reading all manuals. QEL shall not be responsible for any liability arising from auxiliary interfaced equipment nor any damage resulting from the installation or operation of this equipment.

QEL's total liability is contained as above with no other liability expressed or implied as the purchaser is entirely responsible for installation and maintenance of systems.

This warranty is in lieu of all other warranties, expressed or implied, and no representative or person is authorized to represent or assume for QEL any liability in connection with the sales of our products other than that set forth herein.

Note: Due to on-going product development, QEL reserves the right to change specifications without notice and will assume no responsibility for any costs as a result of modifications.

For further information or assistance, contact:

QUATROSENSE ENVIRONMENTAL LTD.

5935 Ottawa Street, PO Box 749

Richmond, Ontario

K0A 2Z0

Tel: (613) 838-4005

Fax: (613) 838-4018

Email: QEL@QELsafety.com

Web: www.QELsafety.com